



High performance 1.9m station for 23cm EME

*How a 1.9m mesh wire dish can
outperform most current 3m+ system*

August 9, 2024

Bill Siino

KB2SA



AGENDA

- Acknowledgements
- Why use a 1.9m dish?
- Hardware highlights
- Simulation highlights
- 1.9m feed on 4.88m dish
- Noteworthy 1.9m 23cm QSOs
- What's next?

Created using
SIMULIA CST Studio Suite®

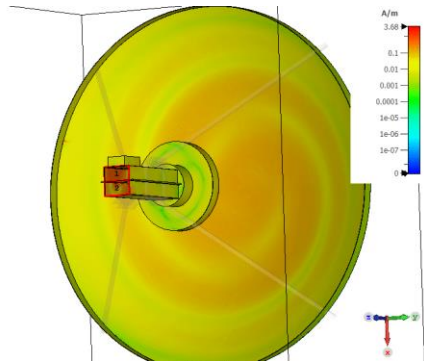

surface current (f=1.296) [1]
Component Axis
Frequency 1.296 GHz
Phase 0°
Maximum (Plot) 3.68112 A/m

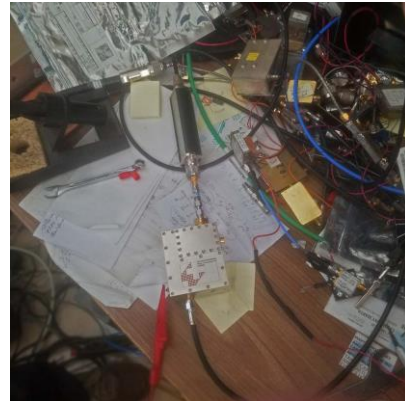

ACKNOWLEDGEMENTS

WHO HELPED

- Rastislav (Rasto) Galuscak (OM6AA) for hundreds of hours of simulation
- Rfspin s.r.o. for the use of SIMULIA CST Studio Suite®
www.rfspin.com
- Bob Atkins (KA1GT) for his idea on using a square to round waveguide taper
- Paul Chominski (WA6PY) for expert advice, measurements and review
- Mats Bengtsson (KD5FZX) for building the optimized “KB2SA feed” and reporting excellent performance using a solid 4.88M, $f/d = 0.39$ dish.



**WHY USE A
1.9M DISH?**



WHY USE A 1.9M DISH?

LESS COULD BE MORE

- Virtually invisible to weather
- Nearly invisible to guests
- Easy to tune & service
- Wide beamwidth hides tracking errors (-1 db when 2° off)
- Short Tx cable to feed (14')

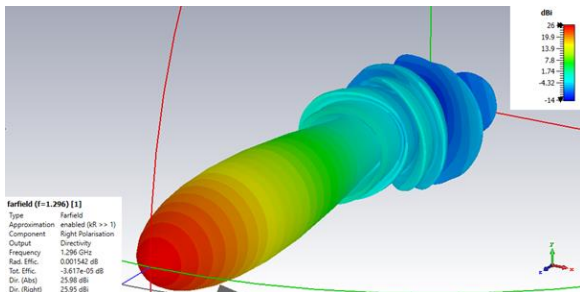



HARDWARE HIGHLIGHTS

Measured (to mesh) vs $Y=AX^2$
Same @ 30° & 90°

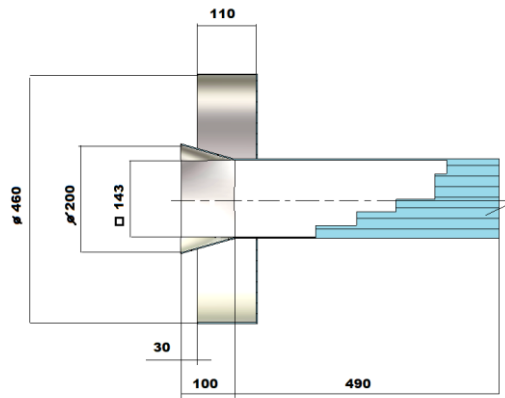
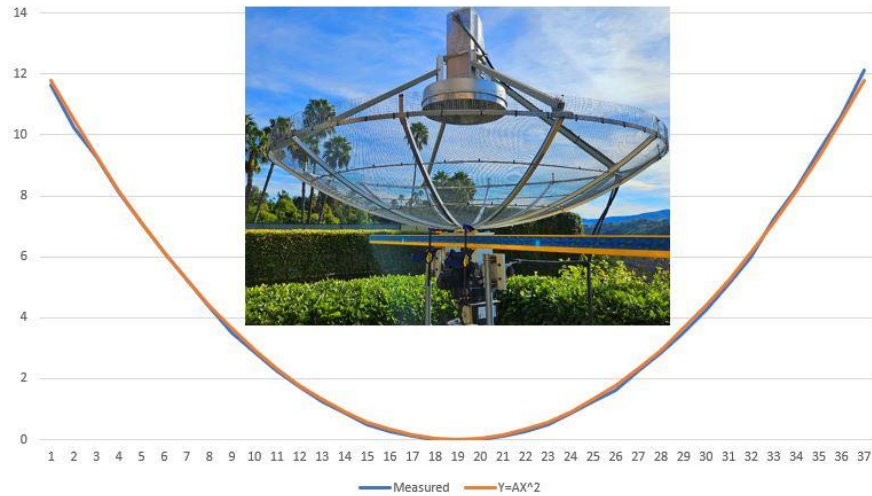

HARDWARE HIGHLIGHTS

The devil's in the details

- **Excellent parabolic surface**
- **Low loss Rx probe to LNA input**
 - Amphenol AD-SMAPSMAP-2*
 - RLC Electronics SR-2MIN-H*
 - HUBER+SUHNER 32_SMA-50-0-1/111_NE*
- **Precise feed construction and dimensions**
- Fiberglass struts
- S12 isolation disk
- Dish collar ring

- D = Dish Diameter = 75.5" (1.92 M)
- Y = Measured every 2" along X
- Subtract Bias from Y to zero in center
- $Y = A * X^2$ (Select A for best fit)
- Actual Focus Point (f) = $1 / (4 * A) = 27.47''$
- Actual $f/D = 27.47'' / 75.5'' = \mathbf{0.364}$

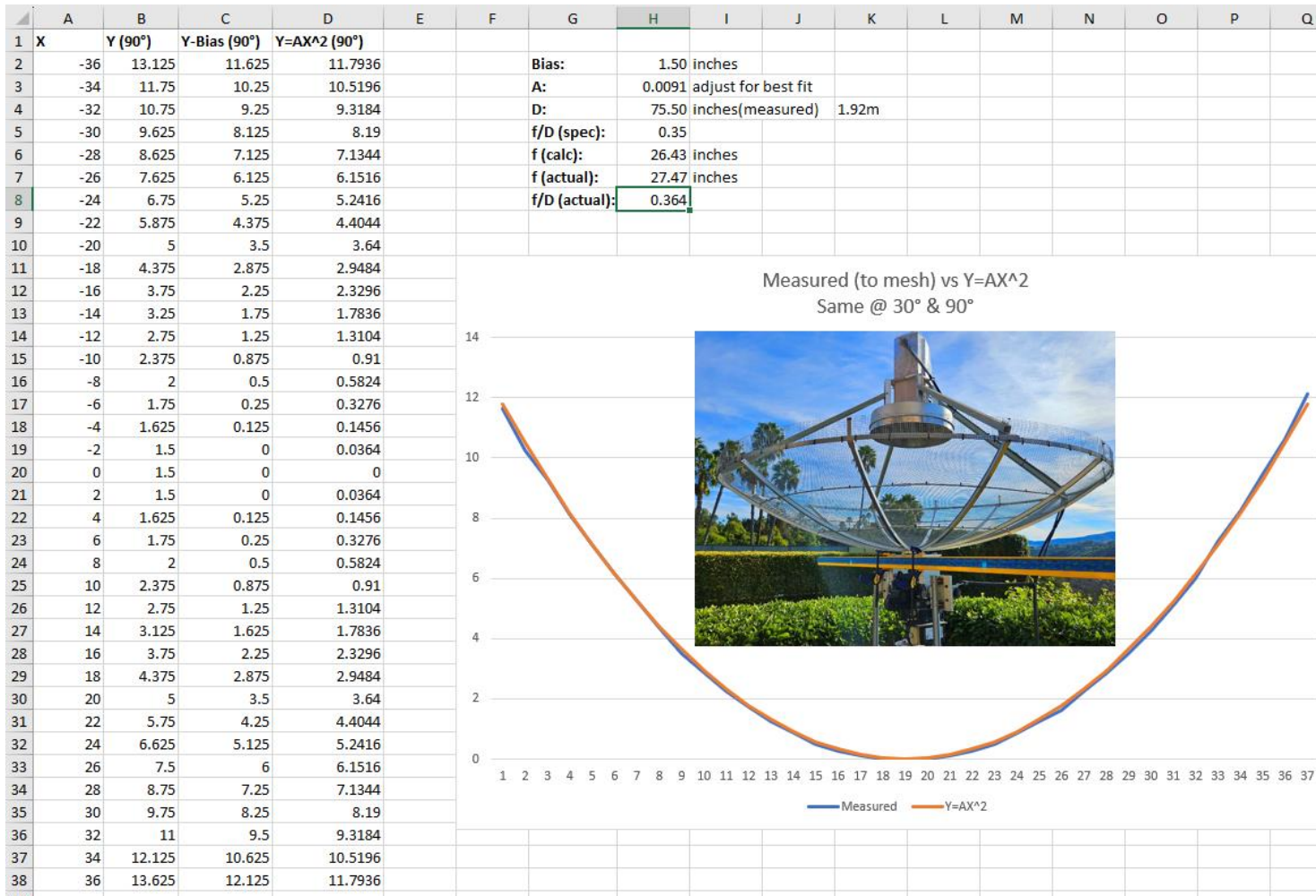

EXCELLENT PARABOLA

Measure It!

- Ruze's equation ($685.81 * (\epsilon/\lambda)^2$) estimates gain loss in db due to RMS surface errors (ϵ). If $\lambda = 230$ mm and $\epsilon = 5$ mm, loss = 0.3 dB.
- The effort to estimate the gain loss is usually far more complex than the effort to fix it.
- Tweak "A" in ideal parabola to best fit measured parabola.
- Correct deformation throughout and calculate actual f and f/D.

ASSUME:

85° F ambient (300K)

LNA NF = 0.25 dB

No TX port noise (S12 is high)

Relay + connector loss = 0.1 dB

- Equivalent LNA noise = $300 * (10^{((0.25+0.1)/10)} - 1) = 25.18K$
- LNA noise = $300 * (10^{(0.25)/10} - 1) = 17.78K$
- Antenna noise @ 30° elevation = 12K

Rx performance loss = $10 * \text{LOG} [(25.18+12) / (17.78+12)] = .96 \text{ dB}$

RX PROBE TO LNA LOSS

1 dB for every 0.1 dB

- With typical 23cm LNA NF and antenna noise, a 0.1 dB loss between the RX probe and LNA input decrease RX sensitivity by almost 1 dB.
- ***6' of LMR-600 on 23cm is 0.3 dB. This would decrease RX sensitivity by 2.46 dB.***

Define:

$$\text{Dish Gain Loss (dB)} = 10 * \text{LOG} (X / (X - 1))$$

$$X = 10 ^ (\text{Mesh Loss (dB)} / 10)$$

$$S = S1 = S2 = 6 \text{ mm}$$

$$D = 2 * R1 = 2 * R2 = 0.55 \text{ mm}$$

$$L = 230 \text{ mm (23 cm wavelength in mm)}$$

$$V = \text{LN} (1 / (1 - \text{EXP} (-\pi * D / S))) = 1.38$$

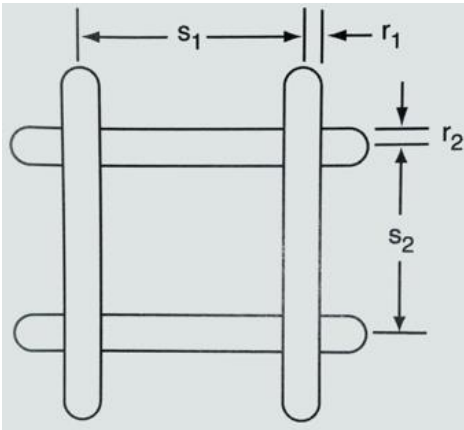

$$\text{Mesh Loss (dB)} = 20 * \text{LOG} (L / (2 * S * V)) = 22.9 \text{ dB}$$

$$X = 10 ^ (22.9 / 10) = 194.98$$

$$\text{Dish Gain Loss (dB)} = 10 * \text{LOG} (194.98 / (194.98 - 1)) = .022 \text{ dB}$$

GAIN LOSS WITH MESH

<0.2 dB if holes < Lambda/10

- S, D specified for popular galvanized fence wire mesh
- Dish gain loss **.022 dB @ 23 cm**



910W @ TX PORT

1200W PA Near Dish

- IC-9700 @ 35% → **3W**
- Q5 Signal 2330PA → **28W**
- 52' LMR-600-DB → **20W**
- Kuhne 1200W → **1,020W**
- 14' LMR-600-FR → **910W**
- All measured with calibrated Bird 4410A w/4410-15 slug and Bird 500-WA-MFN-30 attenuator.

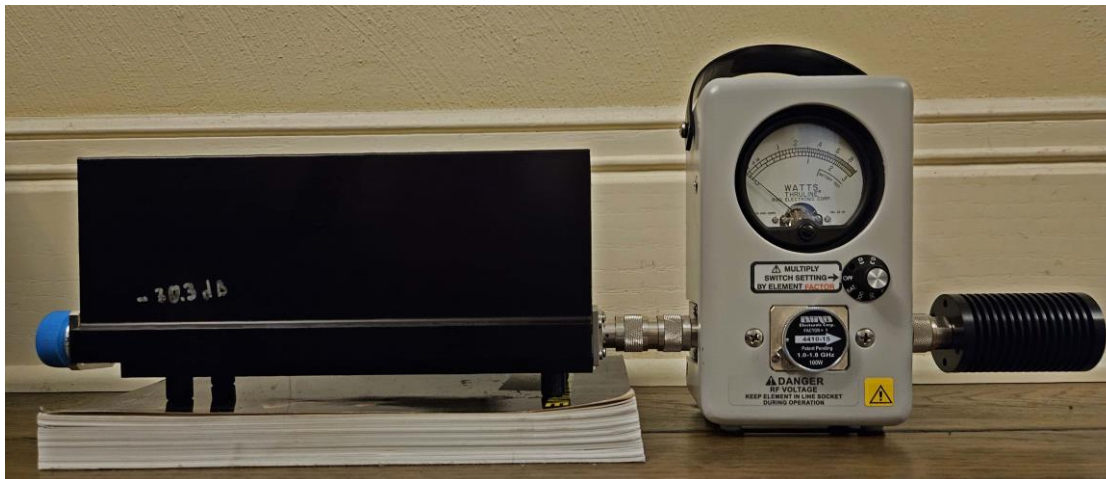

Created using
SIMULIA CST Studio Suite®

e-field (f=1.296) [1]
Component Abs
Frequency 1.296 GHz
Phase 0°
Maximum (Solver) 66.0923 dB(V/m)

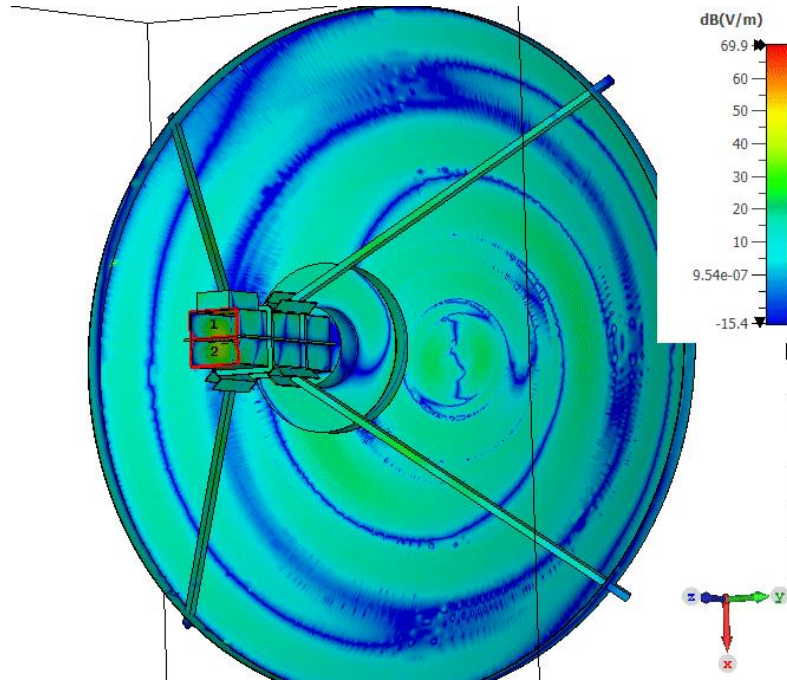

SIMULATION HIGHLIGHTS

RA3AQ (2008) 23 cm

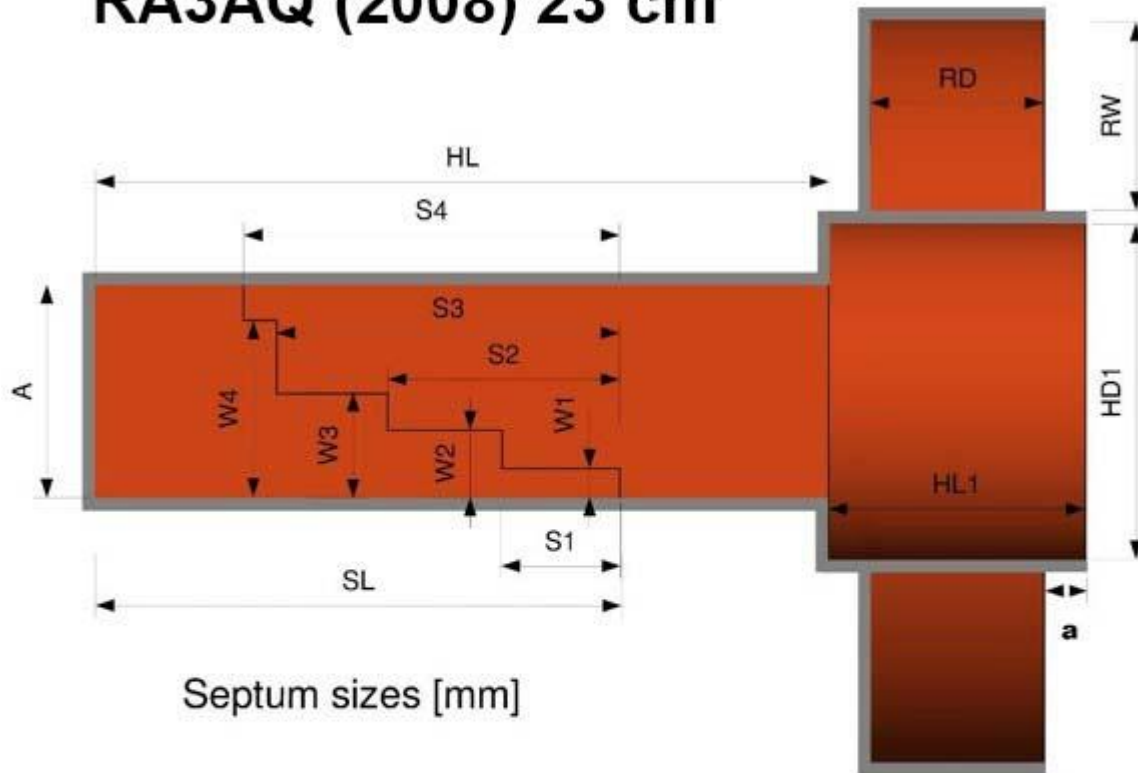

Septum sizes [mm]

F[MHz]	A	HL	SL	W1	W2	W3	W4	S1	S2	S3	S4
1296	143,0	475,0	340,0	22,2	46,9	70,9	117,7	75,6	148,6	220,5	242,3

Output section [mm]

F[MHz]	HD1	HL1	RW	RD
1296	214,0	173,0	118,0	81,0

SIMULATION HIGHLIGHTS



- Simulations start with an RA3AQ-type feed tuned prior to simulations for maximum sun to cold sky with 1.9m mesh wire dish with $f/d = 0.35$
- Dish mesh $S = 6$ mm, $D = 0.55$ mm
- Updated to $RW = 118$ mm, $RD = 60$ mm and $a = 30$ mm based on highest sun to cold sky.
- Feed constructed from a modified RF HAMDESIGN feed.

Absolute

Choke narrows beamwidth & lowers sidelobes

No Choke

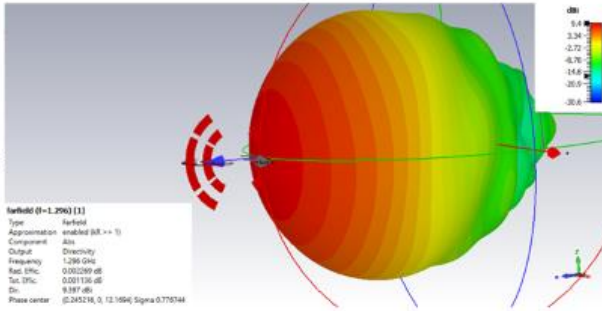

Choke

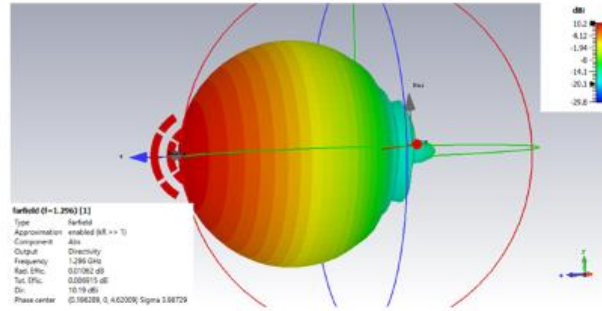

Left Polar

Same results with left polar

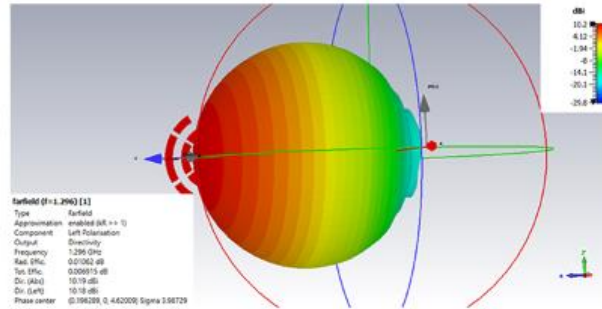
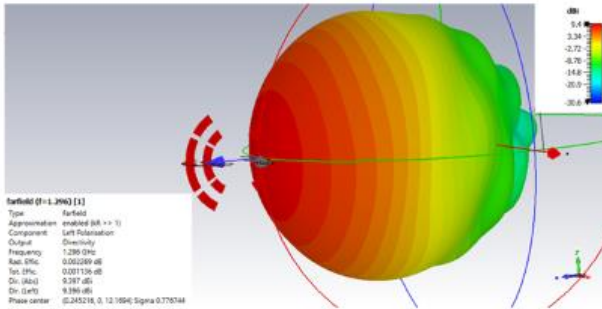

Left Polar

Choke 1 dB less power at dish perimeter with lower sidelobes

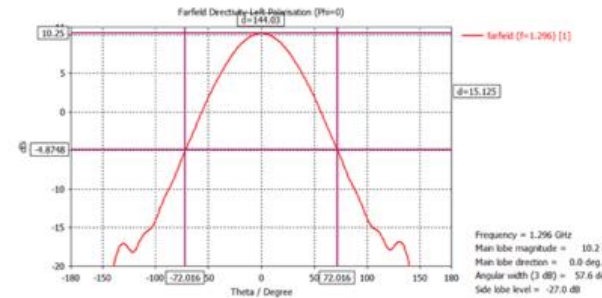
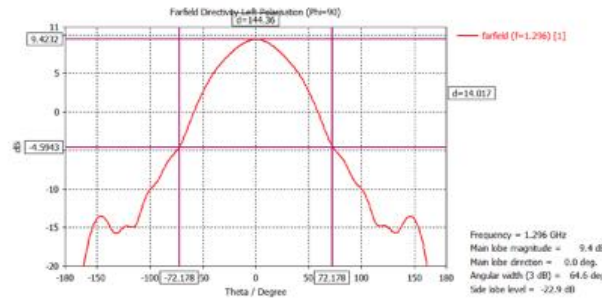

Axial Ratio

AR very good for both.

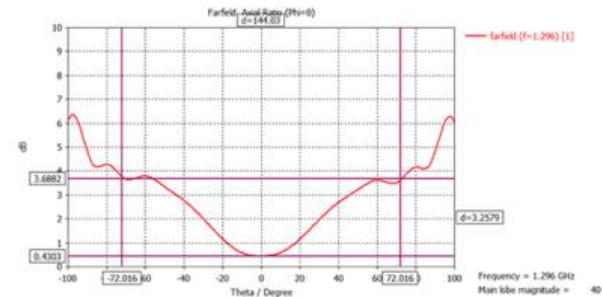
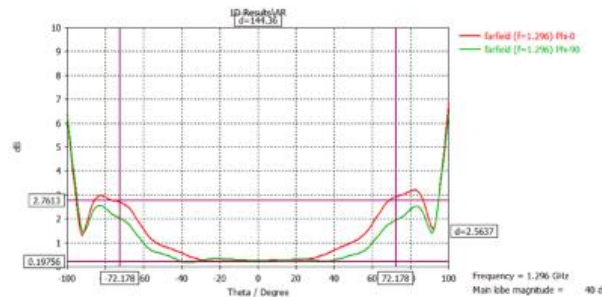

SIMULATION HIGHLIGHTS

Feed Only (no dish)
 With/Without Choke

- Feed only (no dish) shows noticeable narrower beamwidth and lower sidelobes with choke
- 3 db beamwidth reduced from 64.6° to 57.6°
- Sidelobes reduced 4 dB
- Axial ratio good with/without choke

Absolute Profile

Choke lowers sidelobes

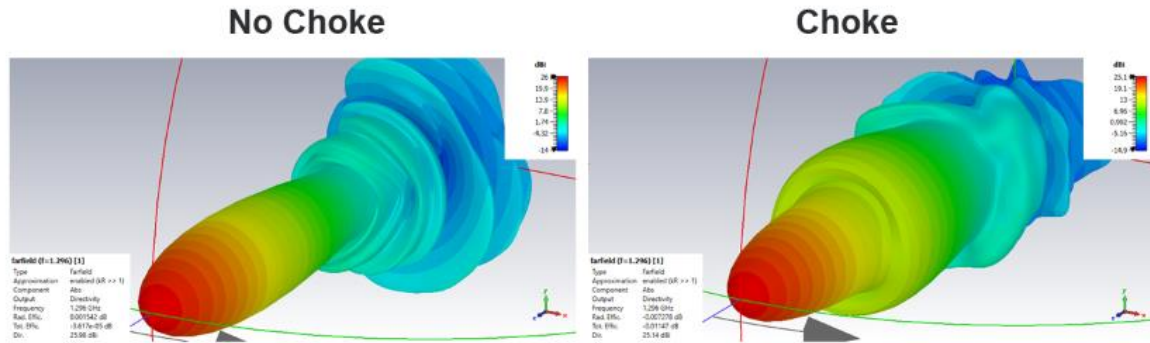

Absolute Front

Choke lowers sidelobes

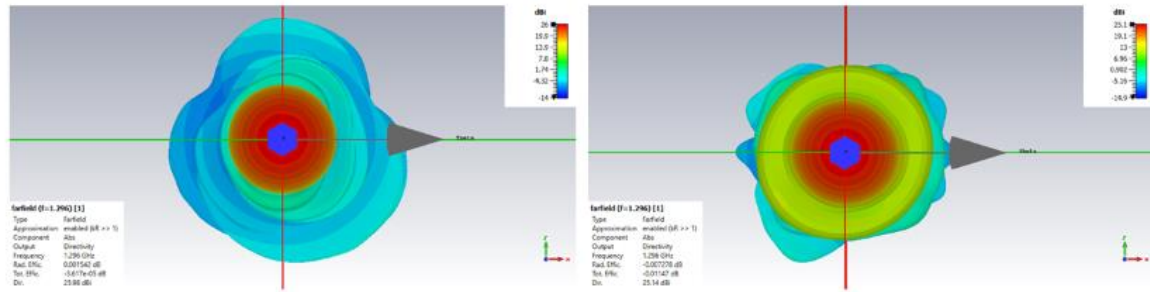

Axial Ratio

AR very good for both

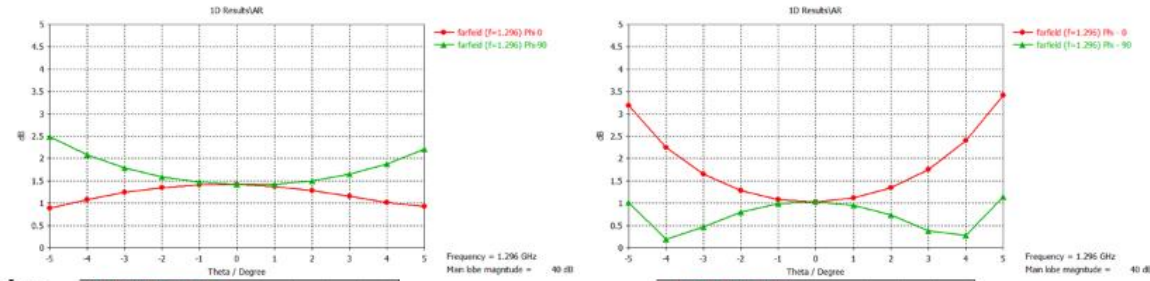

Antenna Noise

Lower sidelobes means lower antenna noise for better RX

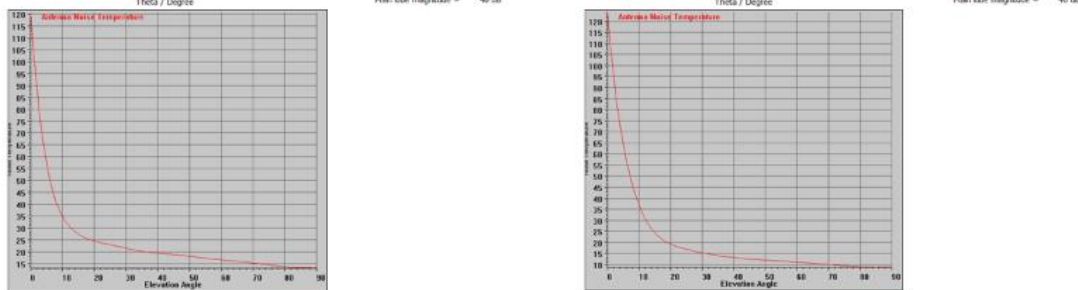

SIMULATION HIGHLIGHTS

Feed + Dish
Fiberglass Struts
With/Without Choke

- Choke lowers sidelobes (as expected from the feed-only behavior)
- Lower sidelobes result in lower antenna noise vs. dish elevation
- Antenna noise calculated with OM6AA Antenna Noise Temperature Calculator (ANTC) fed with simulated radiation patterns.
- $G/T_s \text{ dB} = 10 * \text{LOG} [10^{(G_{\text{max}} \text{ dBi}/10)} / (\text{LNA NF } \kappa + \text{Antenna Noise } \kappa)]$

Absolute Profile

Metal distorts beam and sidelobes. Less with choke that hides some metal

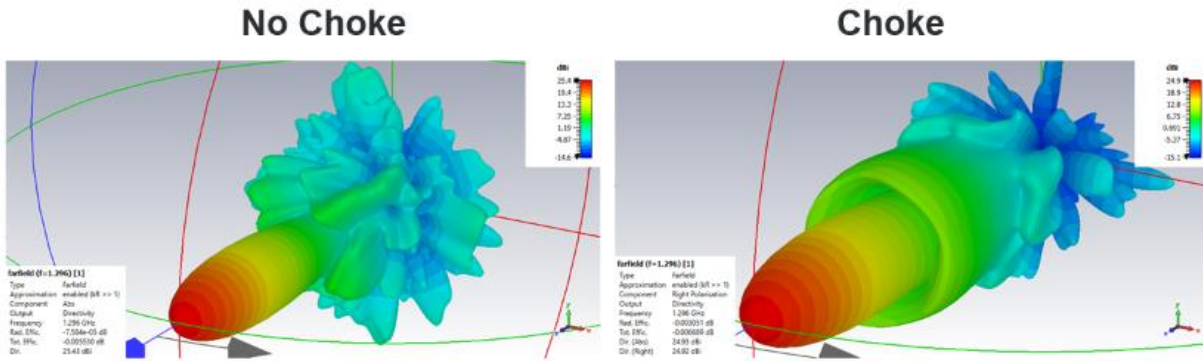

Absolute Front

Metal distorts beam and sidelobes. Less with choke that hides some metal

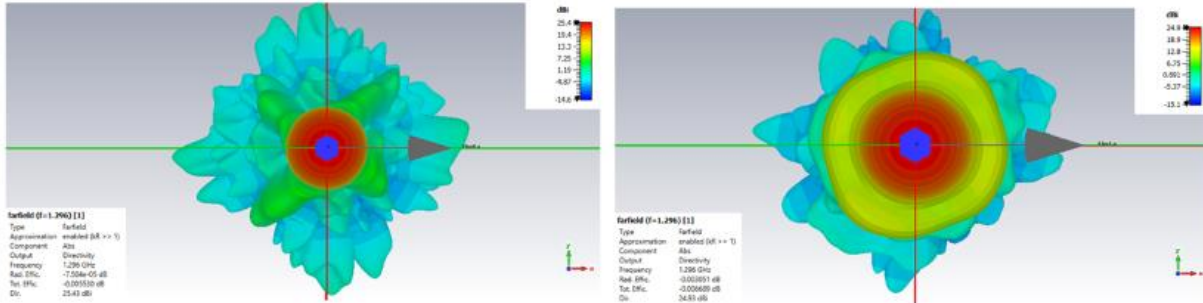

Axial Ratio

AR very good with metal

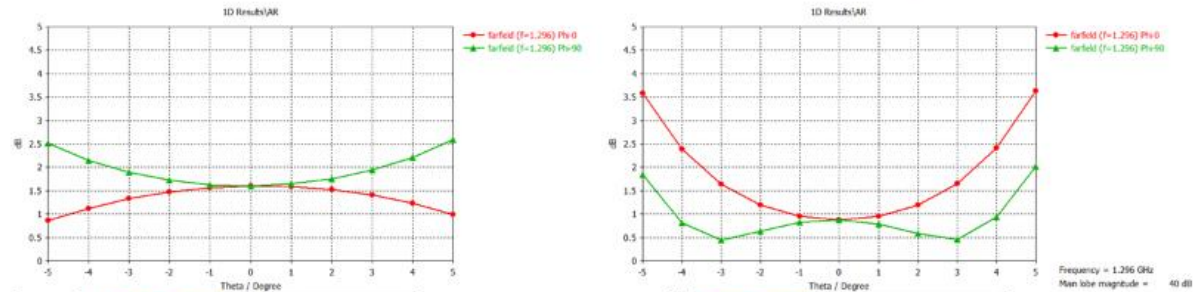

Antenna Noise

Metal has very little effect on noise with choke. Noticeably greater with no choke.

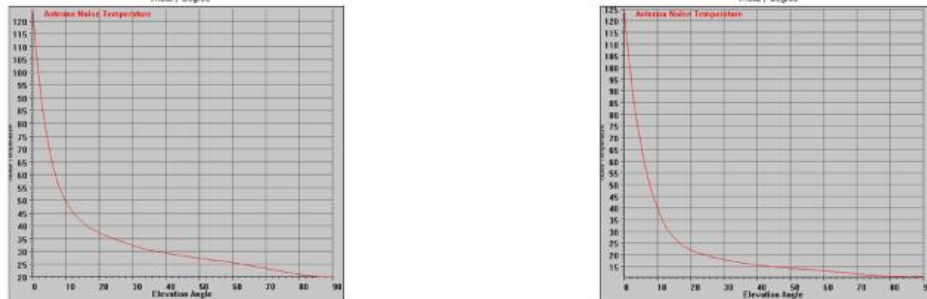

SIMULATION HIGHLIGHTS

Feed + Dish
Aluminum Struts
With/Without Choke

- Aluminum struts distort the beam and sidelobes
- Distortion is less noticeable with choke
- Noise temperature noticeably higher with Aluminum struts, even with choke (e.g., 3K @ 30°)

No Choke

Choke

Simulator Model

Simulia CST
MW Studio.
I-solver used
for Dish+Feed
T-solver for
Feed only.

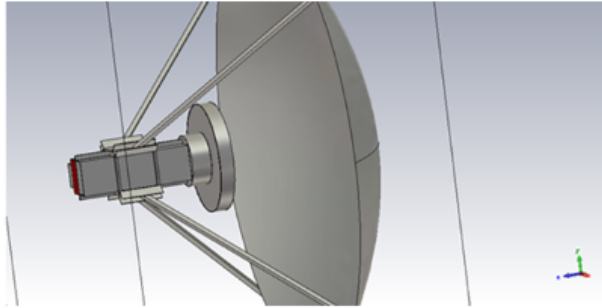
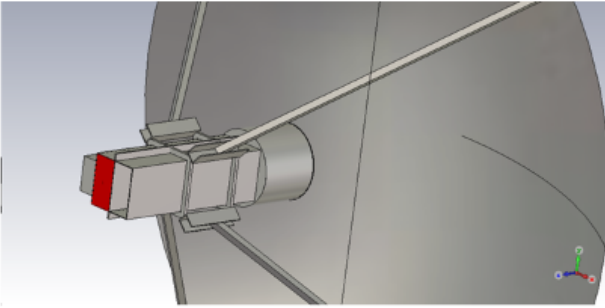

Feed Position

Choke much more sensitive to Feed Position

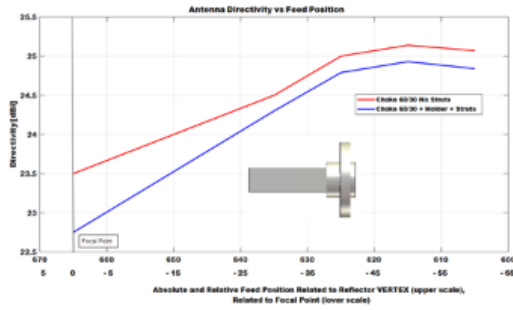
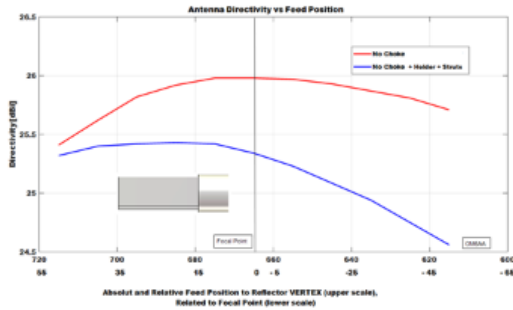

G/Ts, NF = 0dB

Choke is the winner with or without metal struts

No choke can get close, but requires no metal struts

Choke much more sensitive to Feed Position

Z opt = +10 mm no choke; -50 mm choke

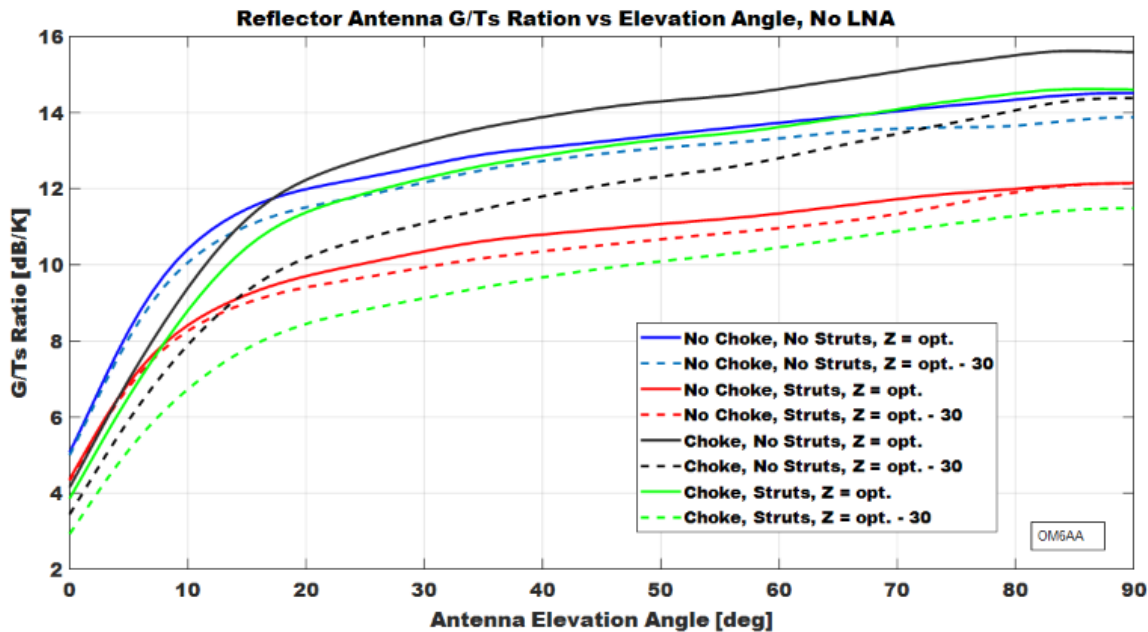

SIMULATION HIGHLIGHTS

Feed + Dish
With/Without Choke
Summary 1 of 3

- Performance more sensitive to feed position with choke.
- Focus point +10 mm outside aperture without choke, -50 mm inside aperture with choke.
- With choke, -30 mm for best RX, -50 mm for best TX.
- Without choke, +10 mm for best RX, +10 mm for best TX.
- If invisible struts and holder, No Choke has about 1 dB more TX but 2 dB less RX.
- Struts and holder affect No Choke much more – nearly 2 dB on RX and 0.5 dB on Tx.

G/Ts, NF = 0.25dB

Added noise from a typical LNA @ 23 cm lowers the advantage of Choke vs No Choke

With metal struts, Choke still > 1 dB better than No Choke

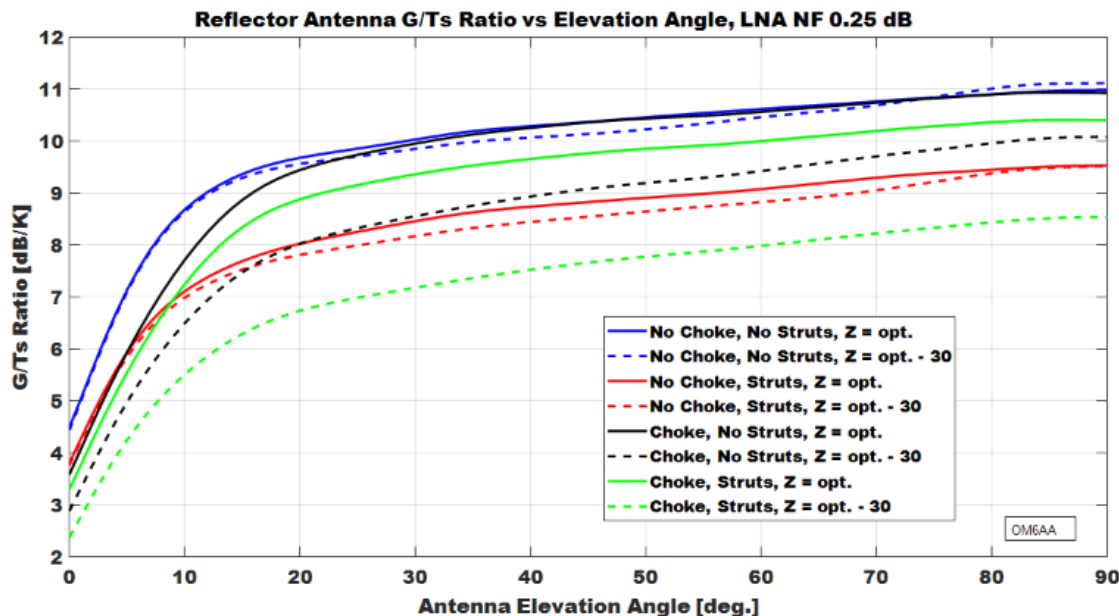

G/Ts, NF = 0.50dB

Higher NF reduces Choke advantage to < 1 dB

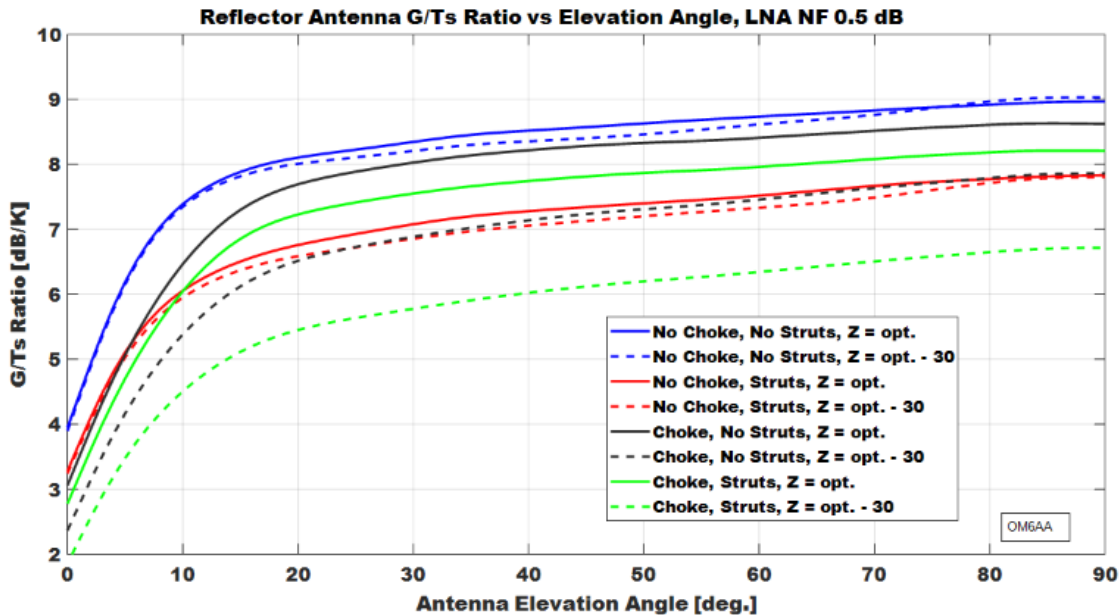

SIMULATION HIGHLIGHTS

Feed + Dish
With/Without Choke
Summary 2 of 3

- Added LNA noise starts to mask advantage of choke and fiberglass struts.
- With LNA NF = 0.25 dB and fiberglass struts, No Choke can slightly outperform choke on RX.
- ***This indicates an RA3AQ-type feed with fiberglass struts may be best with no choke.***

SIMULATION HIGHLIGHTS

Feed + Dish
With/Without Choke
Summary 3 of 3

Gain (G)

With no struts,
No Choke has
0.8 dB higher
gain

With struts,
No Choke has
0.5 dB higher
gain

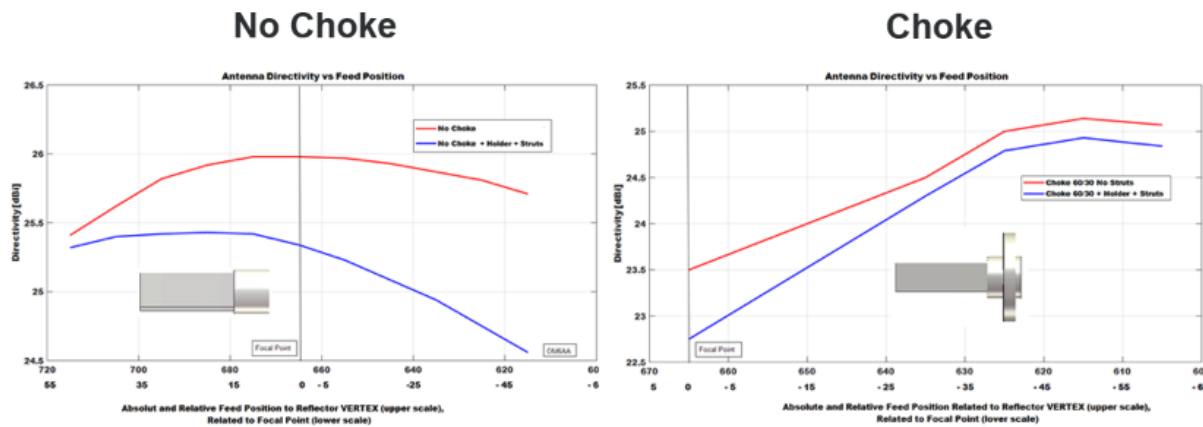

- RA3AQ-type feed without Choke also has better TX.

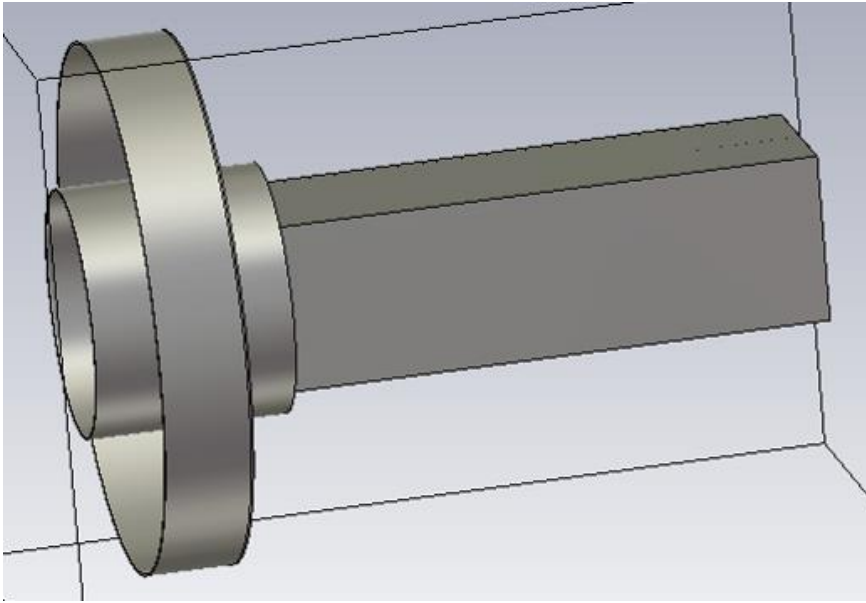

RA3AQ-type

CAN WE IMPROVE
AN RA3AQ-TYPE
FEED FOR A 1.9M
 $F/D = 0.35$ DISH?

Better?

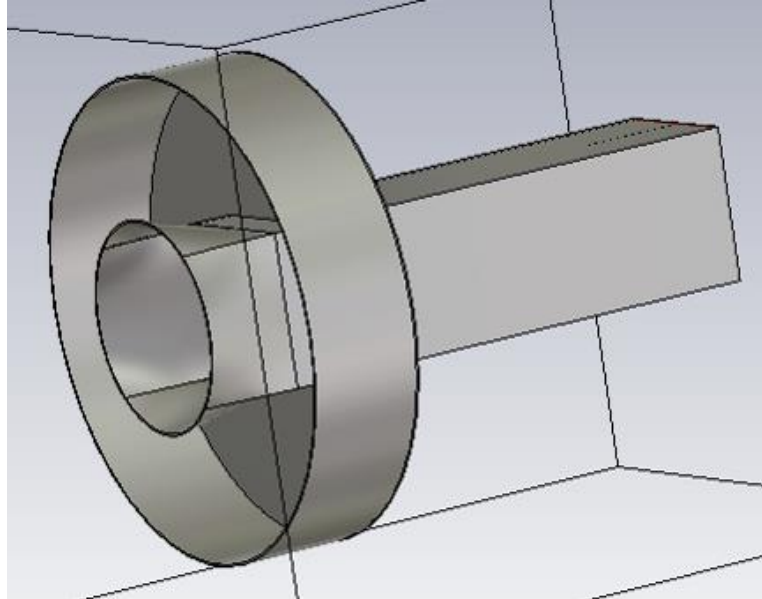

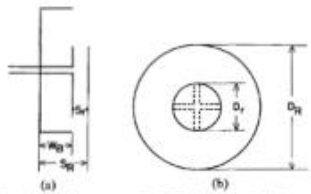

Fig. 1. Two views of a conventional SBF antenna. (a) Front. (b) Cross section.

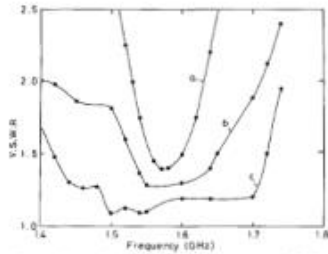

Fig. 3. Characteristics of input VSWR of three types of SBF antennas. a: Conventional SBF antenna with flat large reflector, b: Improved SBF antenna with conical large reflector, c: Improved SBF antenna with conical large reflector and second small reflector.

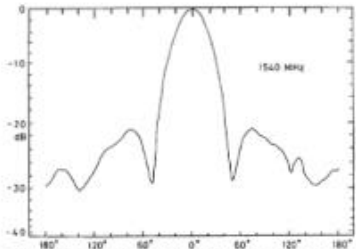

Fig. 2. Radiation pattern of a conventional SBF antenna for 1540 MHz.

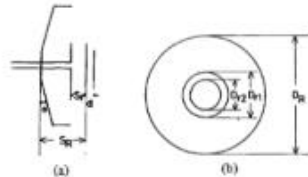
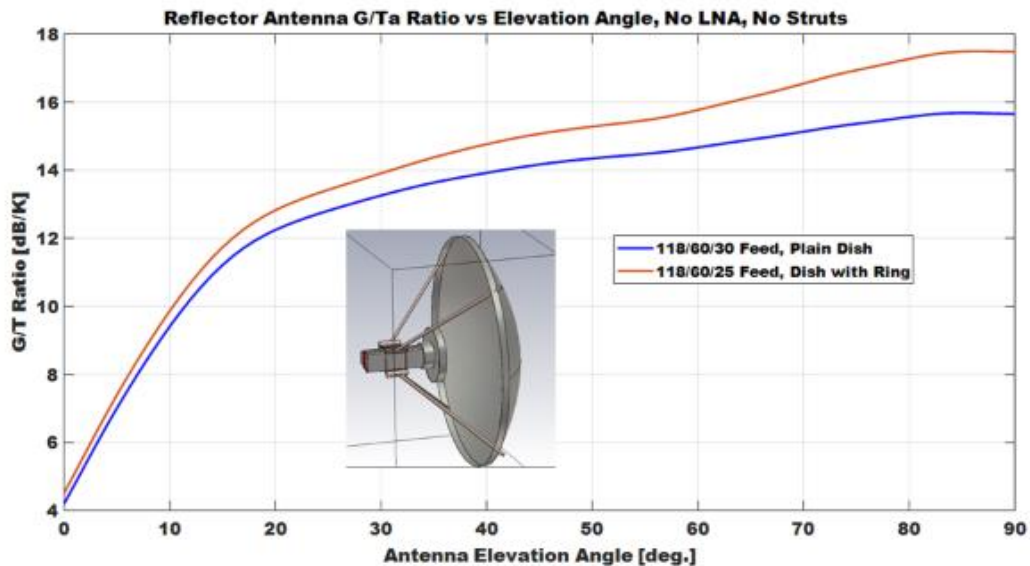

Fig. 4. Two views of improved SBF antenna. (a) Front. (b) Cross section.

SHORT BACKFIRE BEHAVIOR

Feed + Dish
Add Dish Collar Ring
Improvement 1 of 16

- Simulations find the dish + feed combination provided two optimal focal points. This hints that the system may be operating as a Short Backfire Antenna (SBF).
- With a SBF, the choke + dish form a resonating cavity **with reduced sidelobes**. This helps negate the choke obstruction.
- Based on 1983 IEEE paper, an SBF antenna benefits with a Lambda/4 dish collar ring (58 mm).
- > 1 dB G/Ta simulated RX improvement with > 0.5 dB measured sun to cold sky improvement.



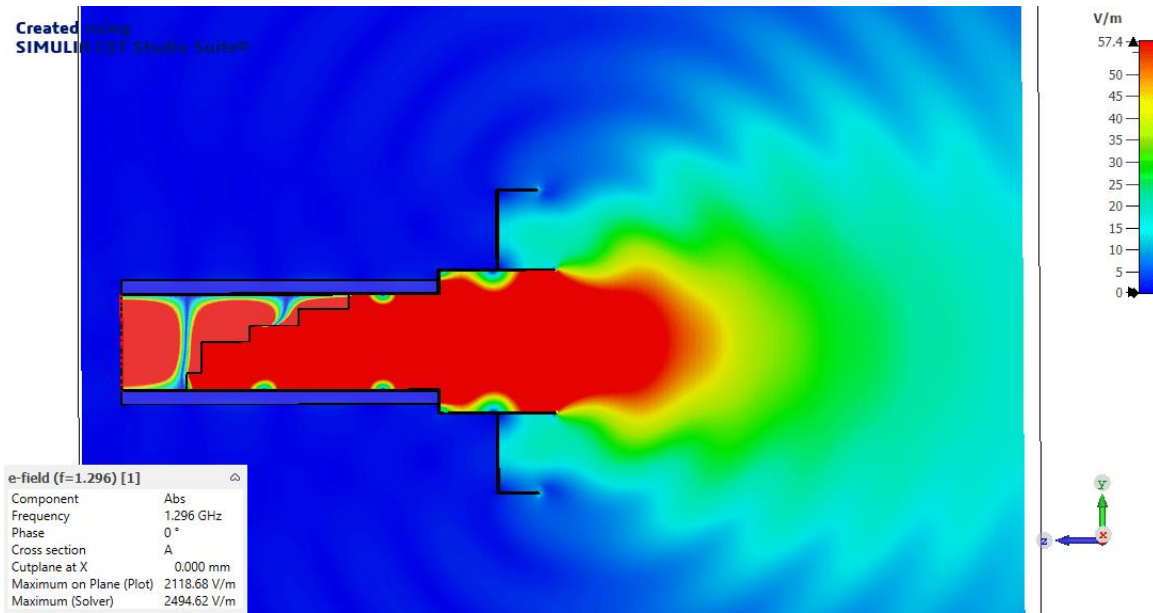

RESONANT WAVES

Feed + Dish
Add Dish Collar Ring
Improvement 2 of 16

- With feed alone, choke fills with the E field.
- When dish added, three partially stationary waves form between dish vertex and feed. These are resonant waves.
- Choke fills with the waves reflected off the dish. **Reversed waves folding on choke rim combine with reflected waves to help reduce sidelobes with collar ring.**
- Disadvantage is S12 reduced from 30 dB to only 14 dB due to dish reflection.

Created using
SIMULIA CST Studio Suite®

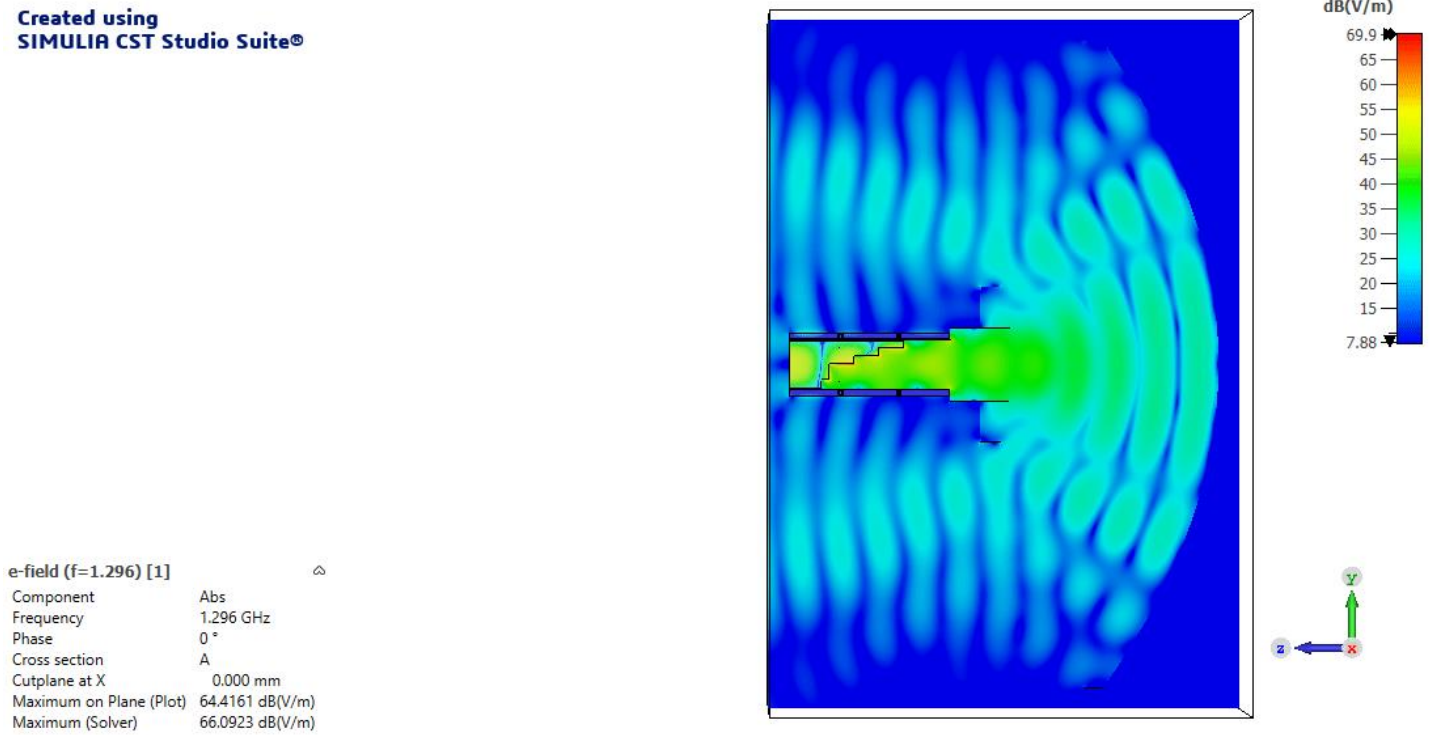

Square to Round Taper

The feed only pattern with a square to round taper (KA1GT) is nearly the same as that from the "perfect" round septum feed (VE4MA/OM6AA)

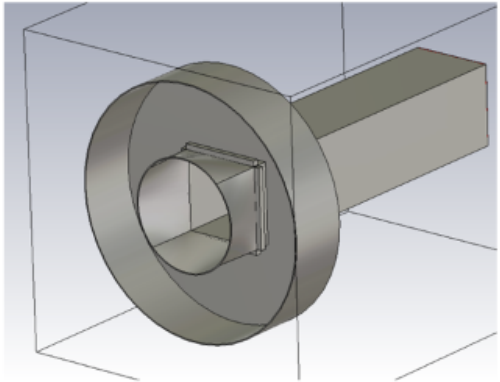

SQUARE TO ROUND TAPER

Feed only
Square to Round Taper
Improvement 3 of 16

Square to Round Feed-only Pattern

Round Feed-only Pattern

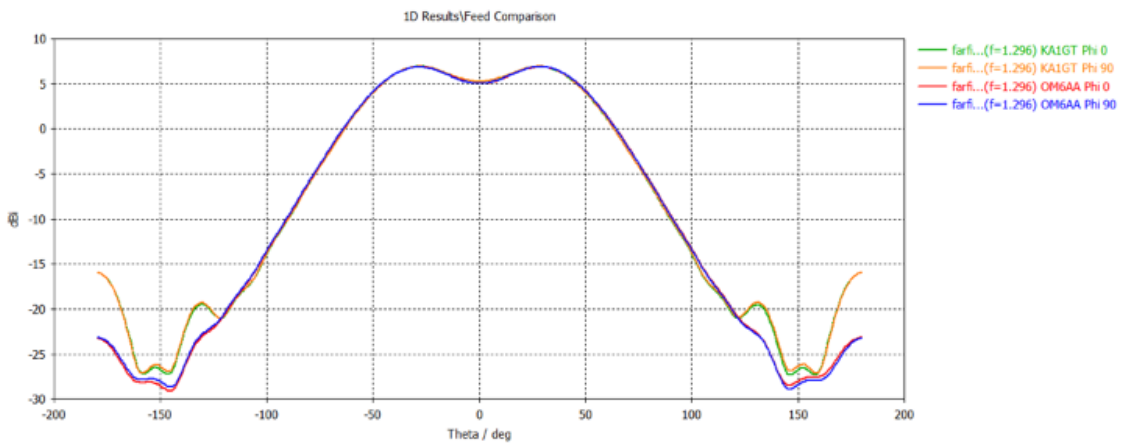
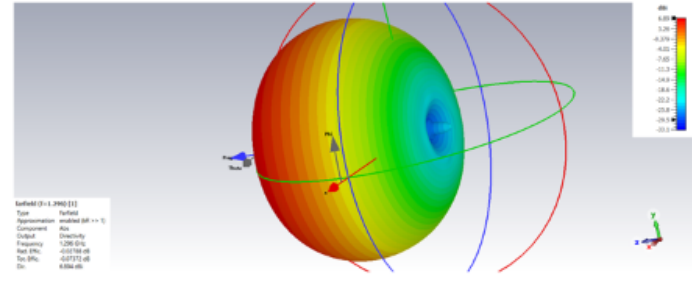
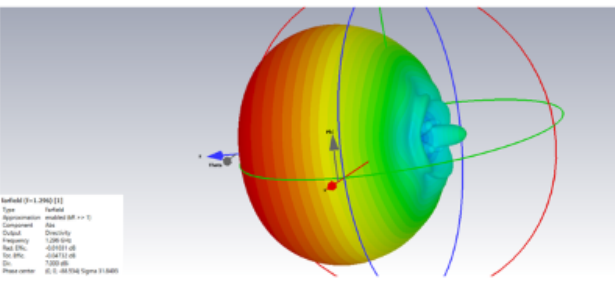

- Based on excellent RX performance observed by KA1GT, the abrupt square to round RA3AQ transition is replaced with a smooth square to round taper.
- ***Feed-only simulation indicates the pattern is nearly identical to a VE4MA/OM6AA round septum.***

Comparing 3 “Best” Feeds

Extensive simulations at optimal focus and choke position yielded two feed competitors: OM6AA and KA1GT

OM6AA Round Septum w/ Super VE4MA Choke

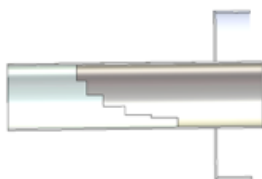

KA1GT Square to Round

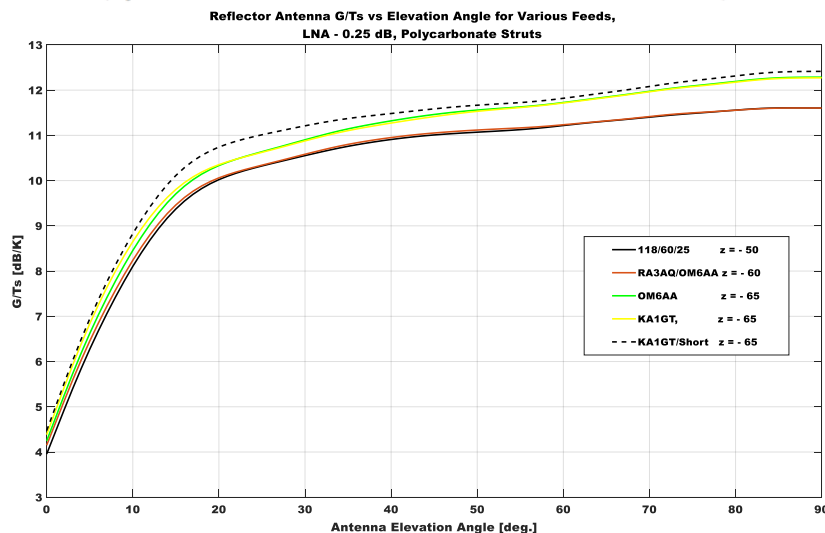
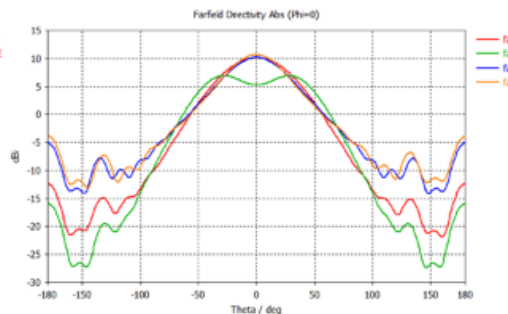
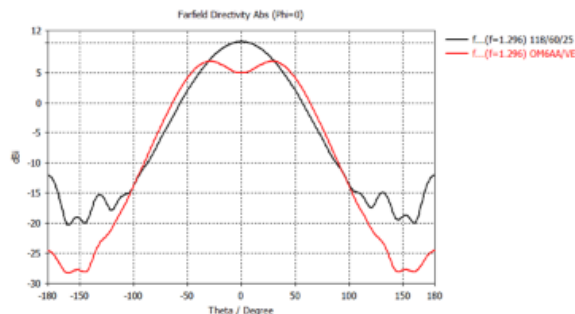
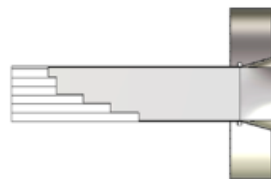

Both feeds have a “fatter” pattern (fill the dish better) with lower sidelobes

Both feeds @ optimal focus provide similar RX performance that exceeds the optimized RA3AQ feed.

At the optimal RX focus, KA1GT feed provides the best TX performance and is the least sensitive to changes in the focal point

FATTER PATTERN

Feed only & Feed + Dish
 Square to Round Taper
 Improvement 4 of 16

- Both the round septum and square to round taper show > 1 dB RX performance increase over the RA3AQ feed.
- Both feeds have a “fatter” pattern that fills the dish better with significantly lower sidelobes.

Antenna Directivity

When comparing the KA1GT system to the 118_60_30 RA3AQ system, we find the KA1GT system has significantly higher TX gain that is less dependent on feed position.

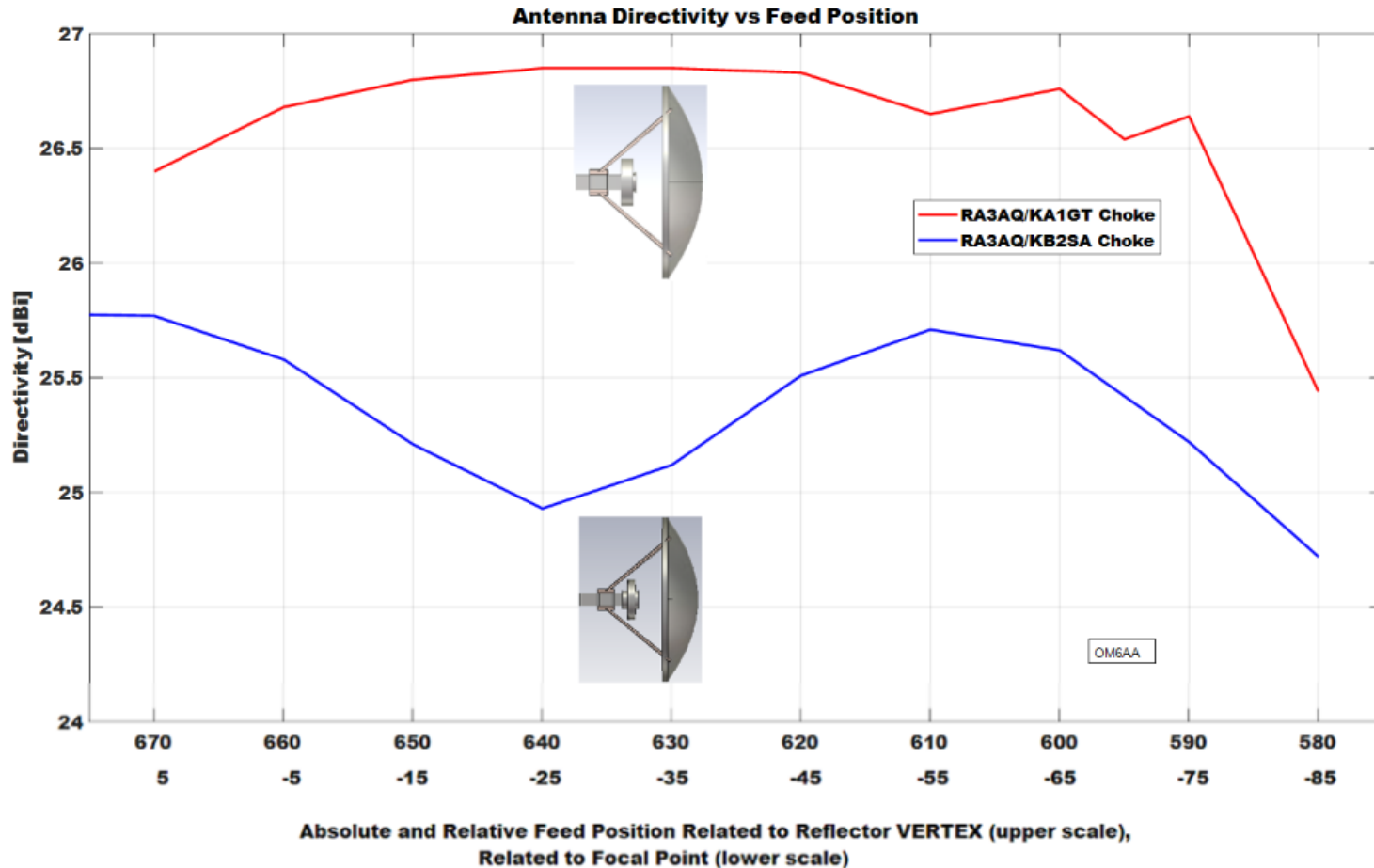

SAME TX AND RX POSITION

Feed + Dish
Square to Round Taper
Improvement 5 of 16

- The smooth square to round taper also shows a significant improvement over the abrupt square to round transition for TX gain.
- TX gain improved 1 dB and is less dependent on feed position.
- ***The optimal feed position is also nearly the same for both RX and TX.***

RX Performance

When comparing the KA1GT system to the 118_60_30 system, we find the KA1GT system has significantly higher RX performance at the optimal focal point. KA1GT also less susceptible to focal point changes.

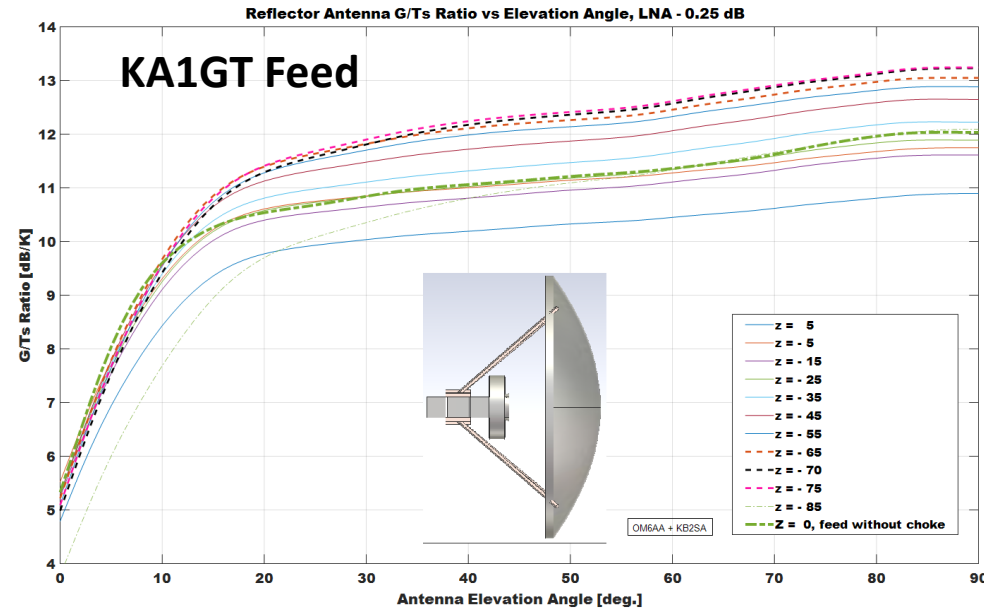
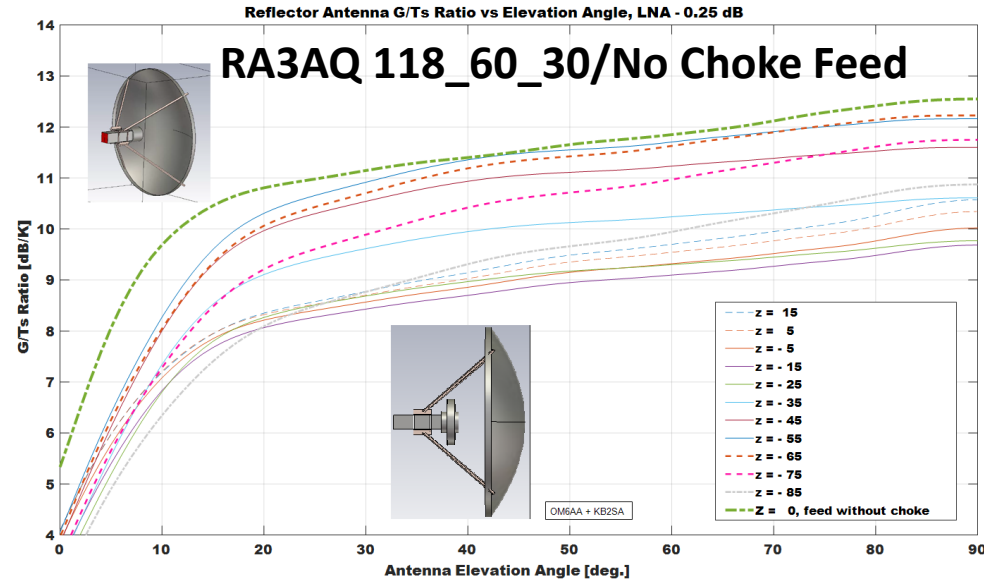

SQUARE TO ROUND TAPER!

Feed + Dish
Square to Round Taper
Improvement 6 of 16

- In summary, the smooth square to round taper has > 1 dB RX performance gain over the abrupt square to round transition.
- The RX performance is also less susceptible to feed position.
- ***RA3AQ feed with No Choke better than Choke.***

Can we shorten the KA1GT feed?

To help lower feed weight, simulations were performed on a shortened KA1GT feed. G/Ts performance is not degraded, but S12 decreased from 20 to 18 dB.

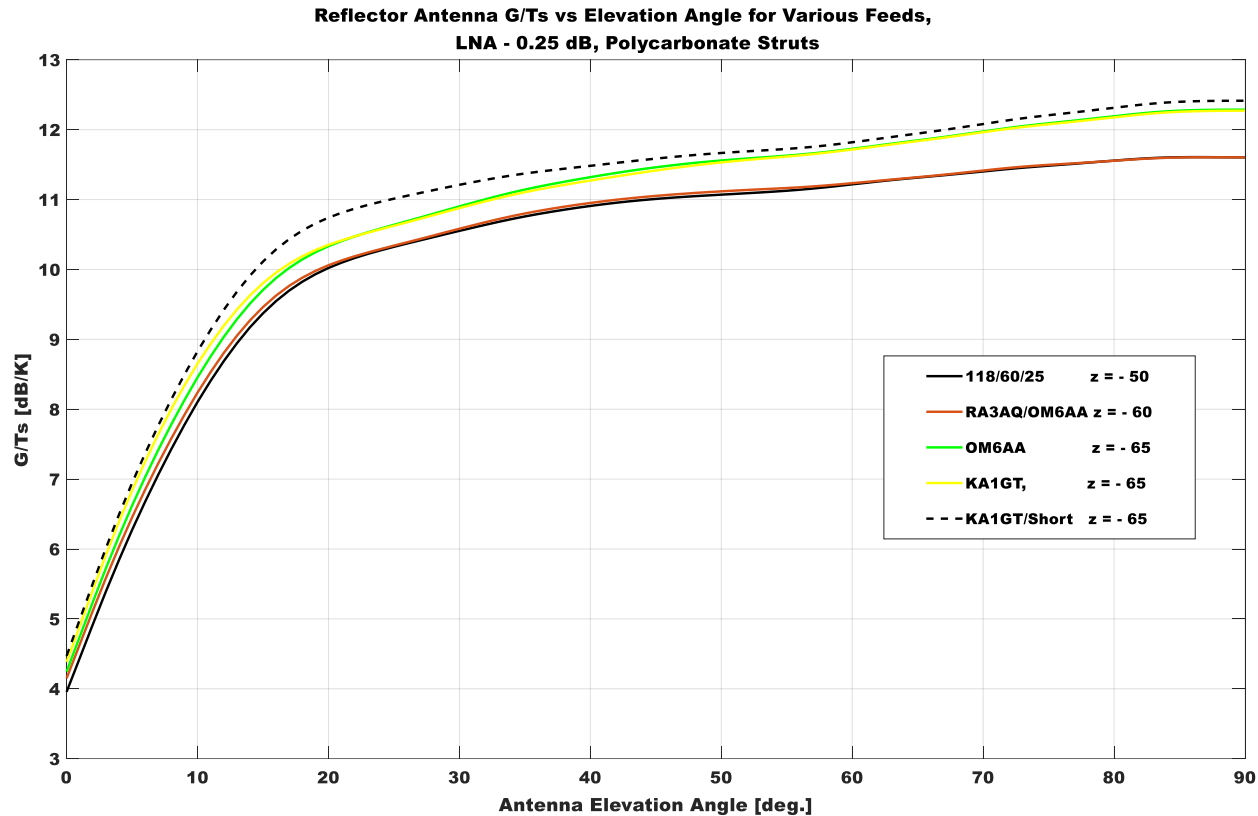

CAN WE SHORTEN FEED?

Feed + Dish
Square to Round Taper
Improvement 7 of 16

- There has been interest in a high-performance lightweight feed for portable operations.
- *An overall feed length of 470 mm outperforms 710 mm.*
- Shorter feed only loses 2 dB S12. We will fix this.

Feed length vs pattern

1. Plot "60/25" is a 60 mm deep choke 25 mm behind the aperture. This is not an optimal pattern.
2. Plot "a 25" is a 110 mm deep choke 25 mm behind the aperture.
3. Plots "s 0" to "s 240" are a 110 mm deep choke 15 mm behind the aperture.
4. "s 240" = overall 710 mm feed length. "s 0" = 470 mm overall feed length. Note little effect on pattern.
5. A choke depth of $\lambda/2$ widens the pattern by reversing the phase of the reflected field.

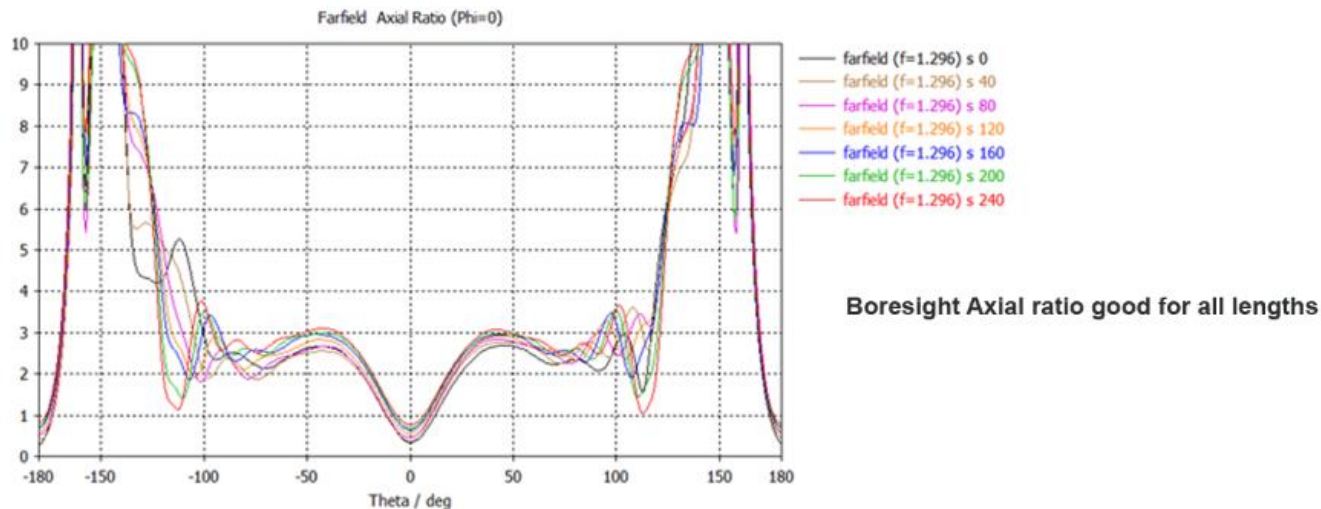
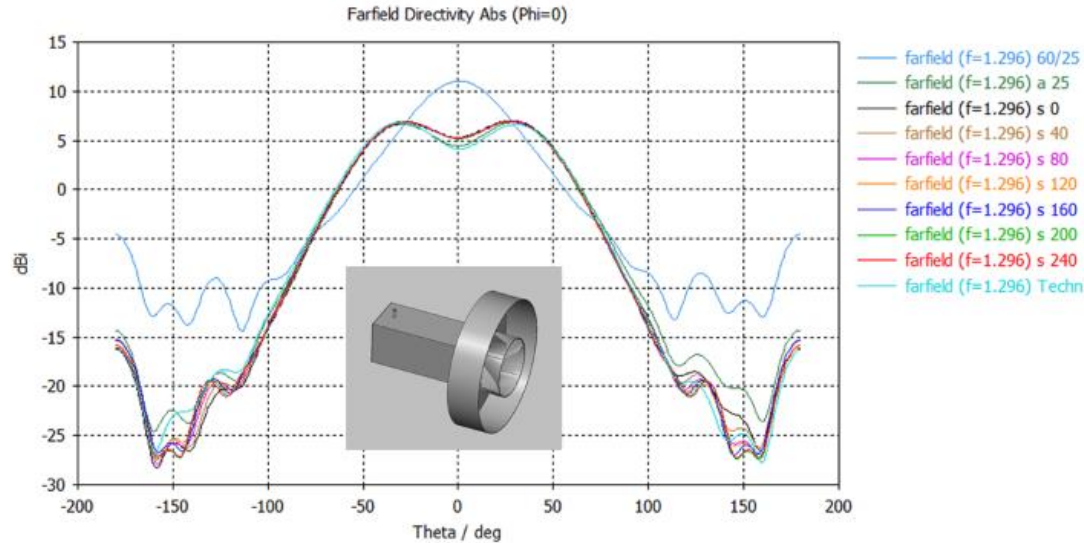

LENGTH & CHOKE DEPTH

Feed only
Square to Round Taper
Improvement 8 of 16

- Extensive simulation confirms feed pattern is nearly identical for overall feed lengths between 710 mm and 470 mm.
- The more critical dimension is the choke depth.
- ***A choke depth near $\lambda/2$ (110 mm) creates a desirable wide pattern due to resonating choke structure.***

Can a deep (110mm choke) improve the RA3AQ performance?

Adding a 110mm deep choke to the RA3AQ feed with an abrupt square to round transition does not improve the feed pattern. There is a waveguide discontinuity between the square and round sections that is not present with the smooth square to round transition.

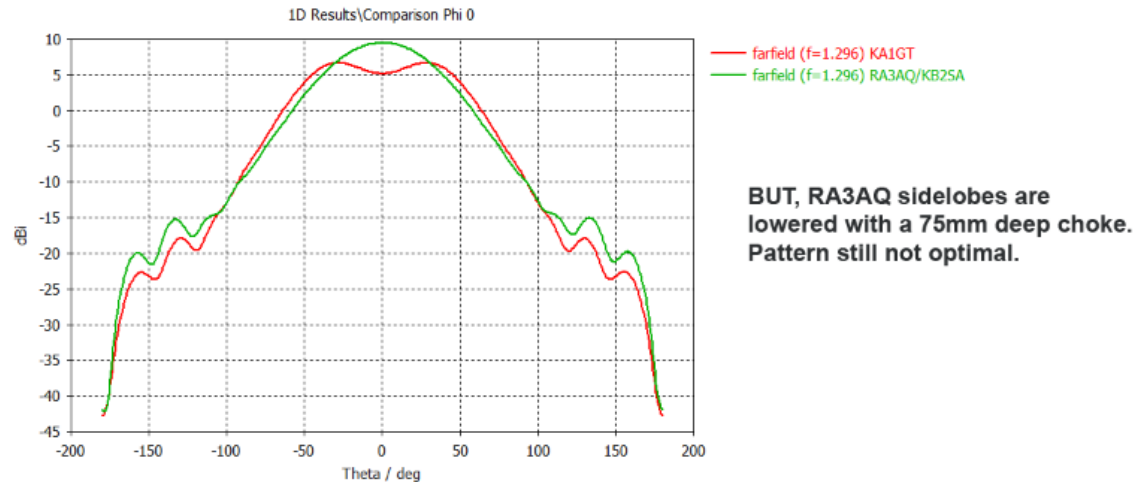
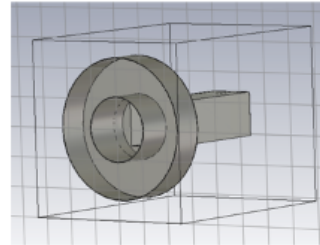
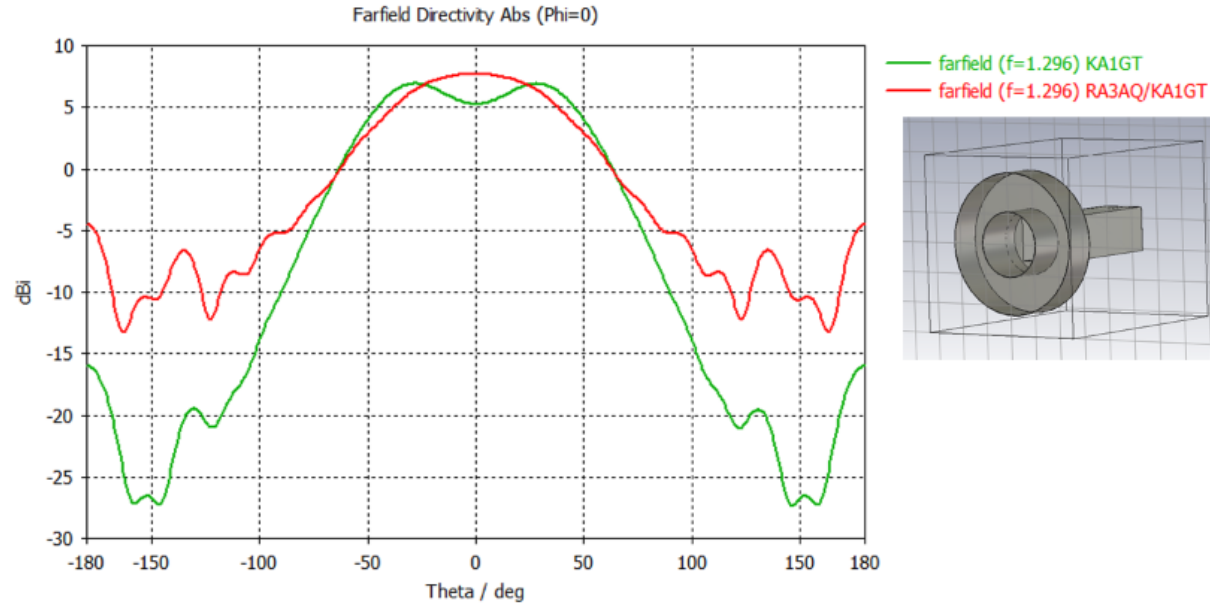

BUT, RA3AQ sidelobes are lowered with a 75mm deep choke. Pattern still not optimal.

DEEP CHOKE ON RA3AQ?

Feed only
Abrupt Square to Round
Improvement 9 of 16

- Can a lambda/2 (110 mm) deep choke improve the RA3AQ feed performance?
- The “fat” pattern cannot be realized. A “waveguide discontinuity” occurs. This is not seen with the square to round taper.
- A 75 mm deep choke does lower sidelobes, but the pattern is still not optimal.

How does the feed pattern vary with choke depth?

Here we show the feed pattern as we vary the choke depth on the KA1GT feed. Each example has the choke set back 25 mm compared with the original KA1GT feed with 110 mm choke set back 15 mm.

Note how a shallow choke depth (80 mm) creates an undesirable pattern. A 100 mm deep choke appears optimal.

This is with the short (470 mm) KA1GT feed variant.

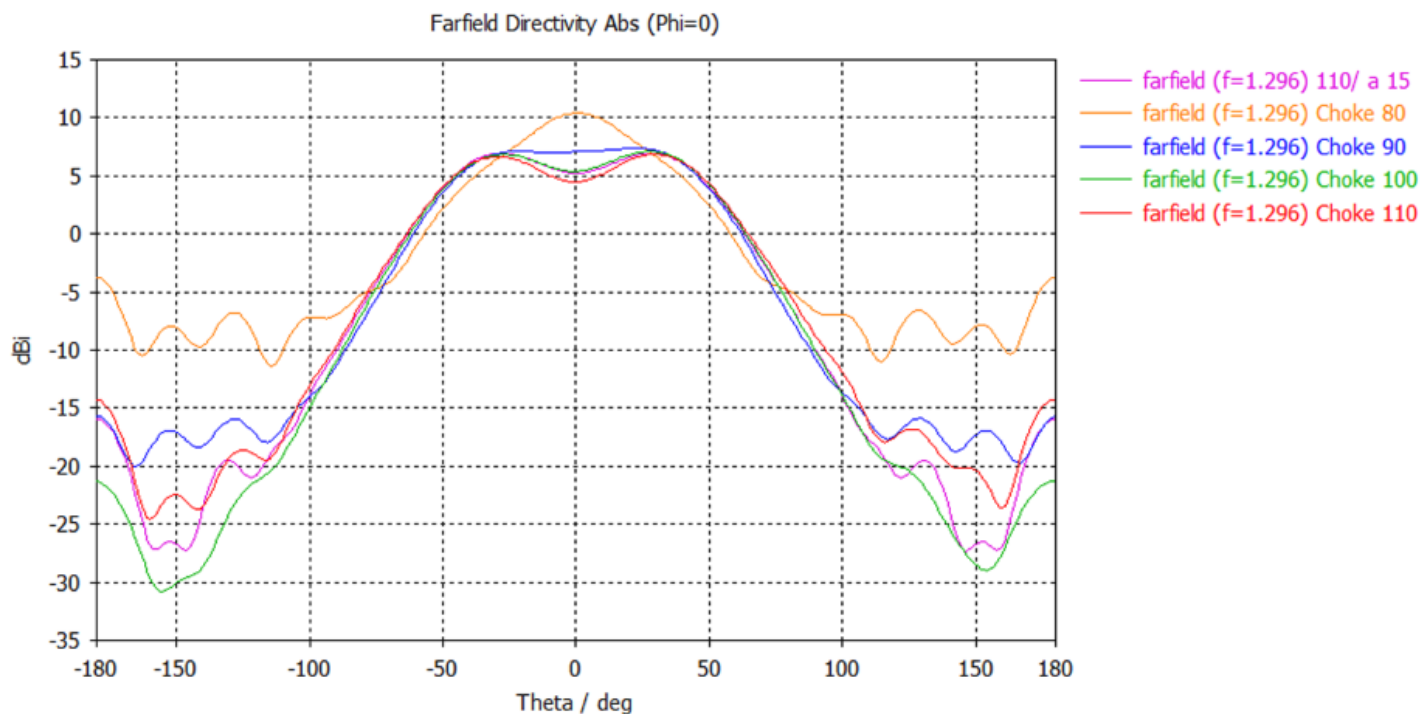

PATTERN VS CHOKE DEPTH

Feed only
Square to Round Taper
Improvement 10 of 16

- Feed shows the desirable “fat” pattern as choke depth increases.
- Pattern flattens noticeably @ 90 mm.
- As choke depth increases, pattern stays flat and sidelobes decrease and then start rising.

Differs slightly from KA1GT feed as shown

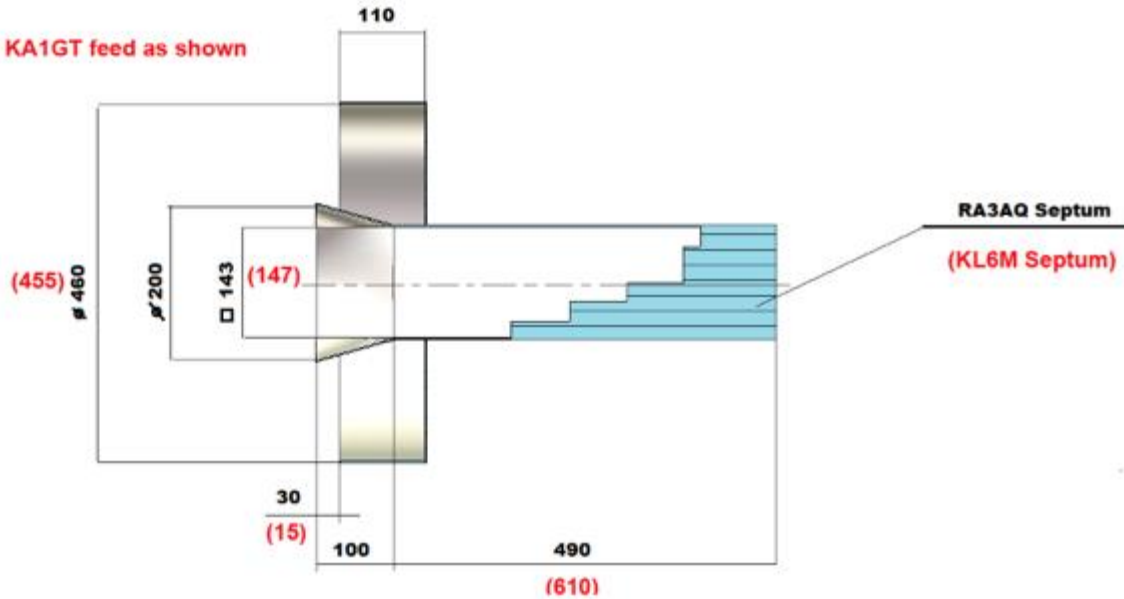

Reflector Antenna G/Ts vs Elevation Angle for Various Feeds,
LNA - 0.25 dB, Polycarbonate Struts

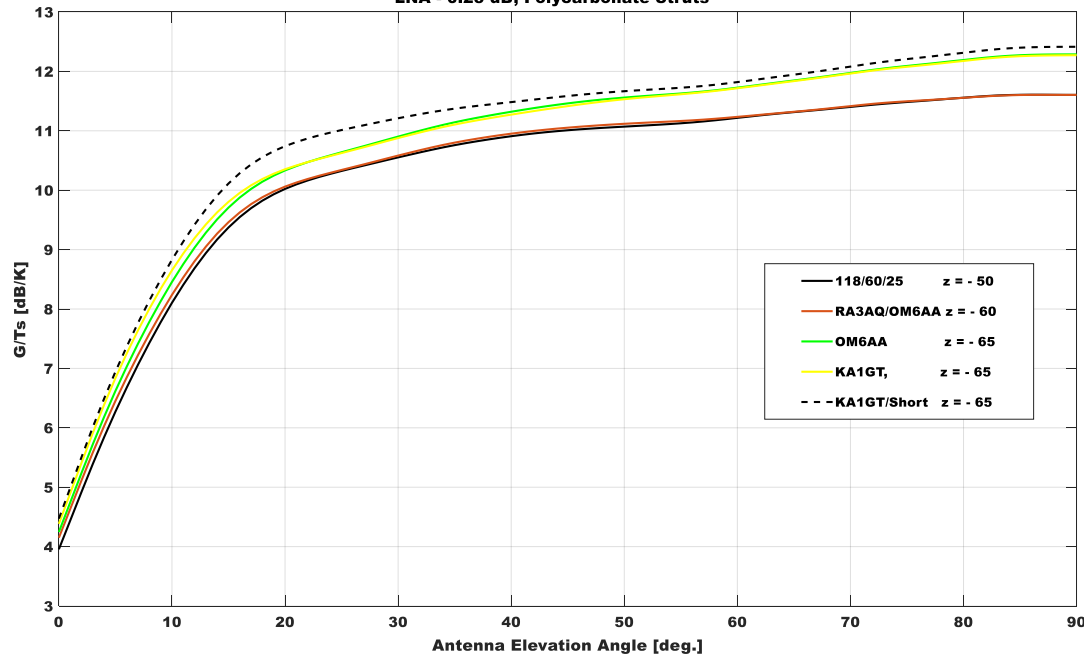

LET'S SUMMARIZE

Feed + Dish
Square to Round Taper
Improvement 11 of 16

- A very high-performance 23cm feed for a 1.9m $f/d = 0.35$ dish starts with an RA3AQ septum and adds a 110 mm deep choke and square to round taper.
- Optimal dimensions are very similar to that found experimentally by KA1GT (choke setback tuned to f/d).
- ***A total feed length of 470 mm is noticeably better than 710 mm (590 mm shown in the figure).***
- Optimal focal point is approximately 65 mm inside the feed.

MEASURED:

85° F ambient (300K)

LNA NF = 0.25 dB

S12 = 14 dB

Relay + connector loss = 0.1 dB

- RX noise from TX port = $300 / 10^{(14/10)} = 12\text{K}$
- Equivalent LNA noise = $300 * (10^{((0.25+0.1)/10)} - 1) = 25\text{K}$
- Antenna noise @ 30° elevation = 12K

Total noise = 12K + 25K + 12K = 49K

If we can remove the 12K noise from the TX port we can realize $10 * \text{LOG} [49/(49-12)] = 1.2 \text{ dB increased RX sensitivity.}$

WHAT ABOUT S12?

Feed + Dish
Square to Round Taper
Improvement 12 of 16

- Earlier we saw that the isolation between the RX and TX port (S12) was significantly reduced when the dish is present with a square to round taper (14 dB measured).
- Assuming 85° F (300K) ambient and .25 dB LNA NF, RX sensitivity is reduced 1.2 dB due to 300K noise on the TX port from 50-ohm termination.

S12 is significantly degraded with the addition of the flare. -14 dB was measured. -15dB seen in simulation and varies with focal point.

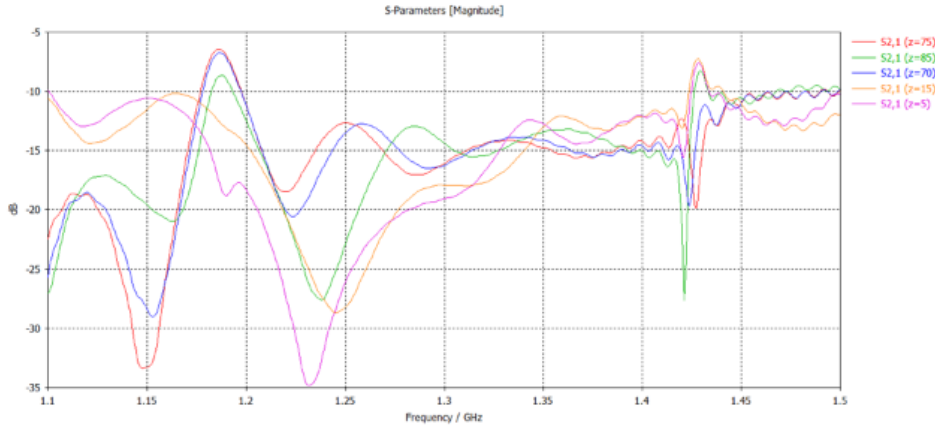

RECOVER S12 WITH DISK

Feed + Dish
Square to Round taper
Improvement 13 of 16

With degraded S12, noise on the TX port appears at the RX port. This increased the RX noise floor nearly 1 dB. A 50mm disk centered 45mm inside the flare lowered this TX noise. Dimensions selected by experimentation.

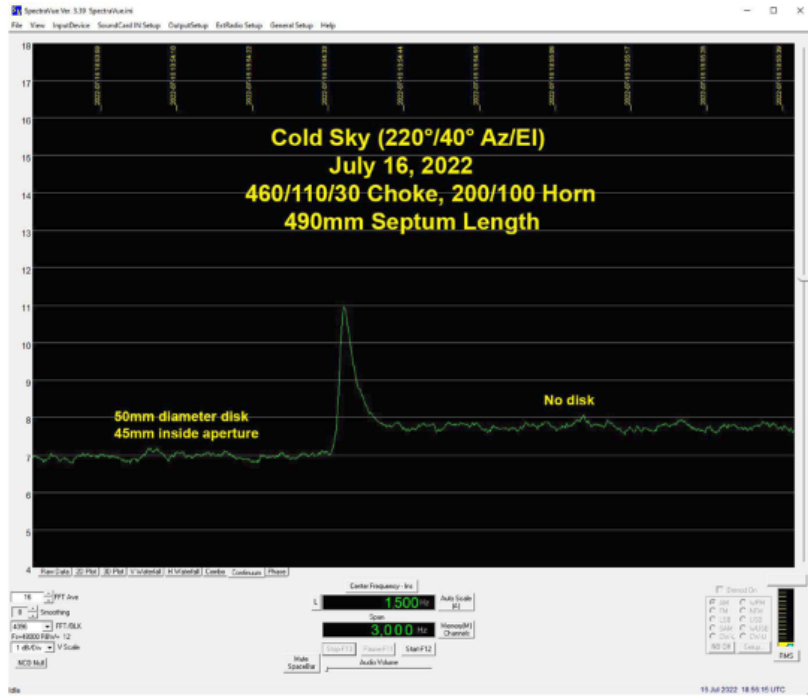

- A 50 mm metal disk centered 45 mm inside the taper increases S12 enough to eliminate the TX port noise on the RX port.
- RX sensitivity increased nearly 1 dB.

Simulations varied the disk diameter and placement to help characterize the behavior.

S12?

Z	1	2
65	45	50
65	45	45
65	45	55
65	40	45
65	40	50
65	40	55
65	50	45
65	50	50
65	50	55

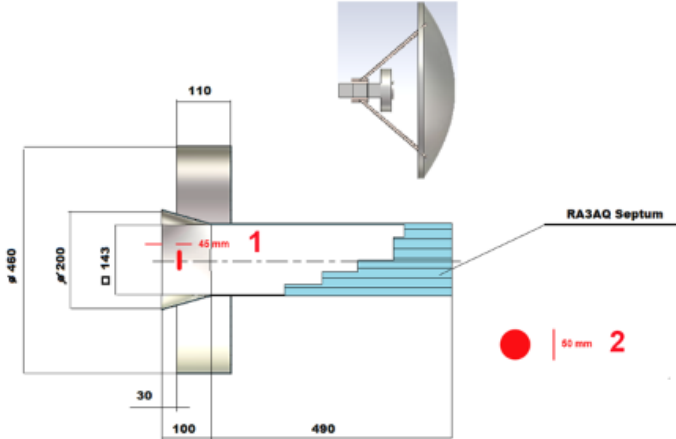

DISK NO EFFECT ON G/T

Feed + Dish
 Square to Round taper
 Improvement 14 of 16

- Disk diameter between 45 and 55 mm placed 40 to 50 mm inside taper has no effect on G/Ts.

Simulation found the disk placement and diameter did not change the overall G/Ts.

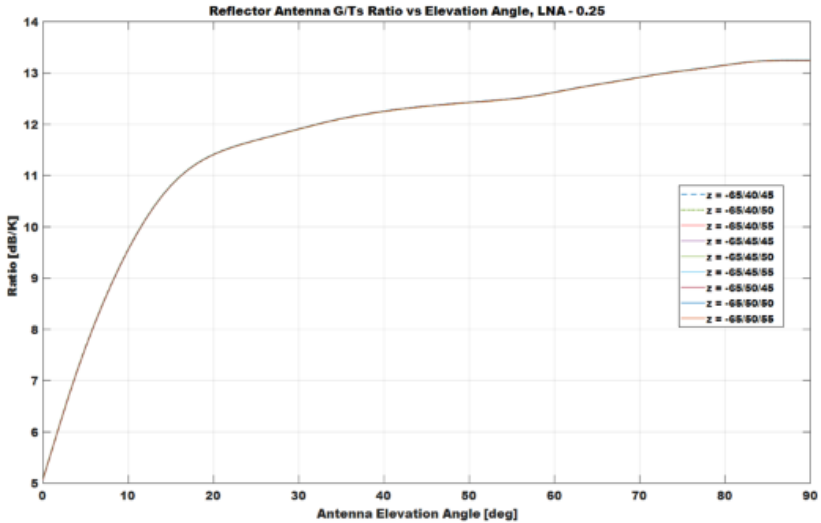

Simulations confirmed the 50mm disk 45mm inside the flare (45i/50d) is very good (-30dB), with 45i/45d and 50i/50d possibly being slightly better (-32dB)

S12 DISK SIZE & POSITION

Feed + Dish
Square to Round taper
Improvement 15 of 16

- S12 increased from 14 dB to > 30 dB with 45 – 50 mm diameter disk placed 45 – 50 mm inside flare.

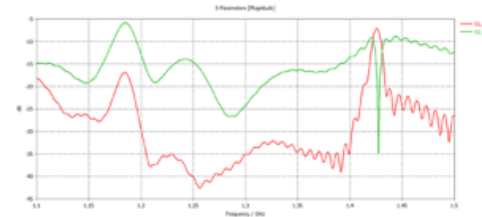

40i/45d

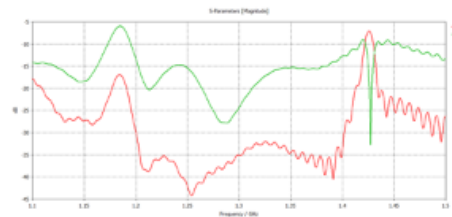

40i/50d

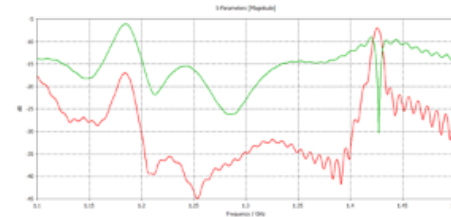

40i/55d

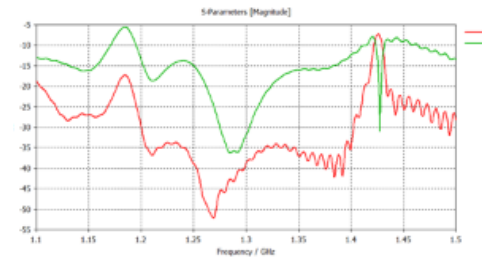

45i/45d

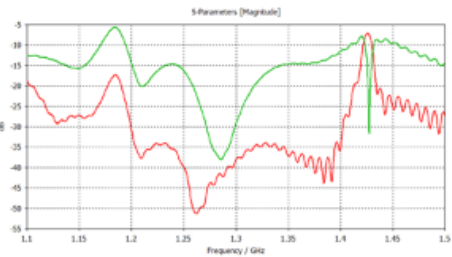

45i/50d

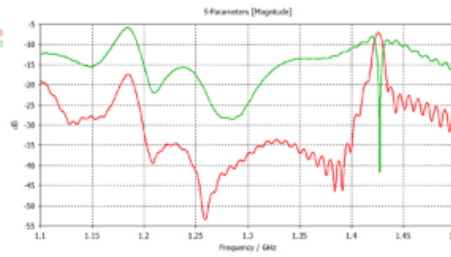

45i/55d

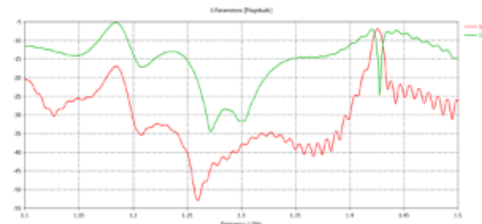

50i/45d

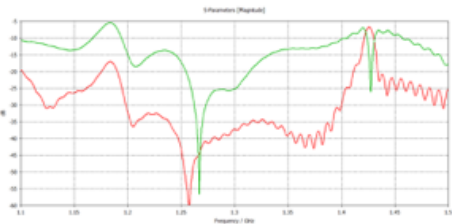

50i/50d

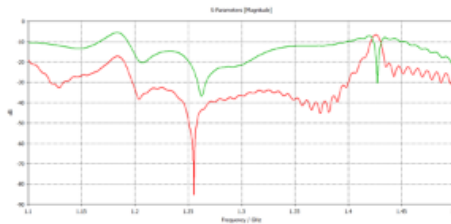

50i/55d

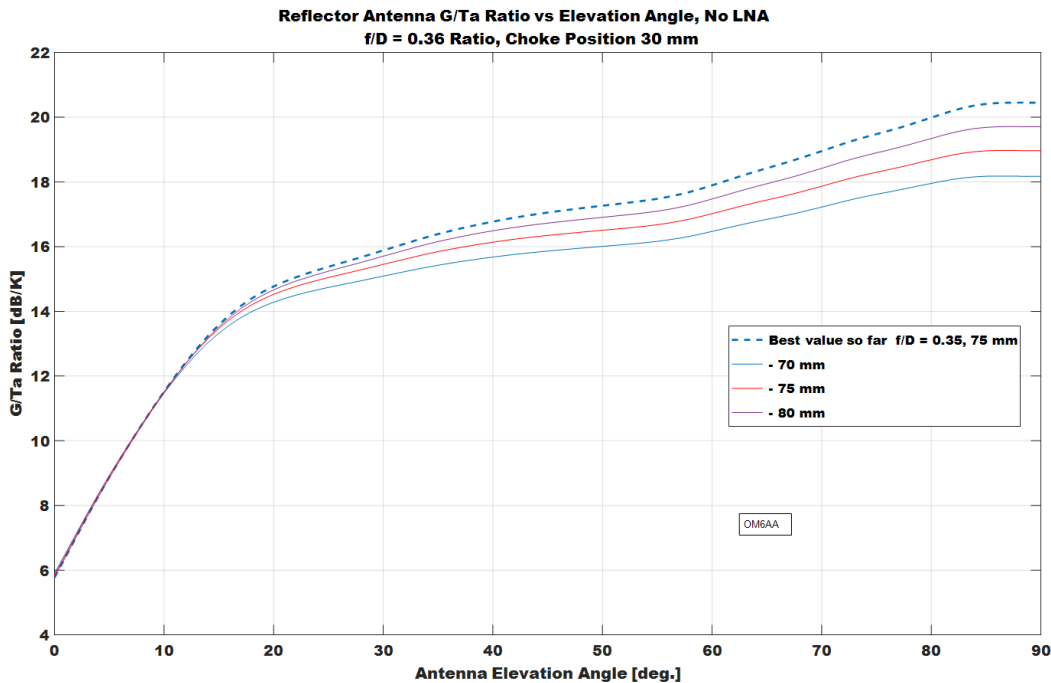
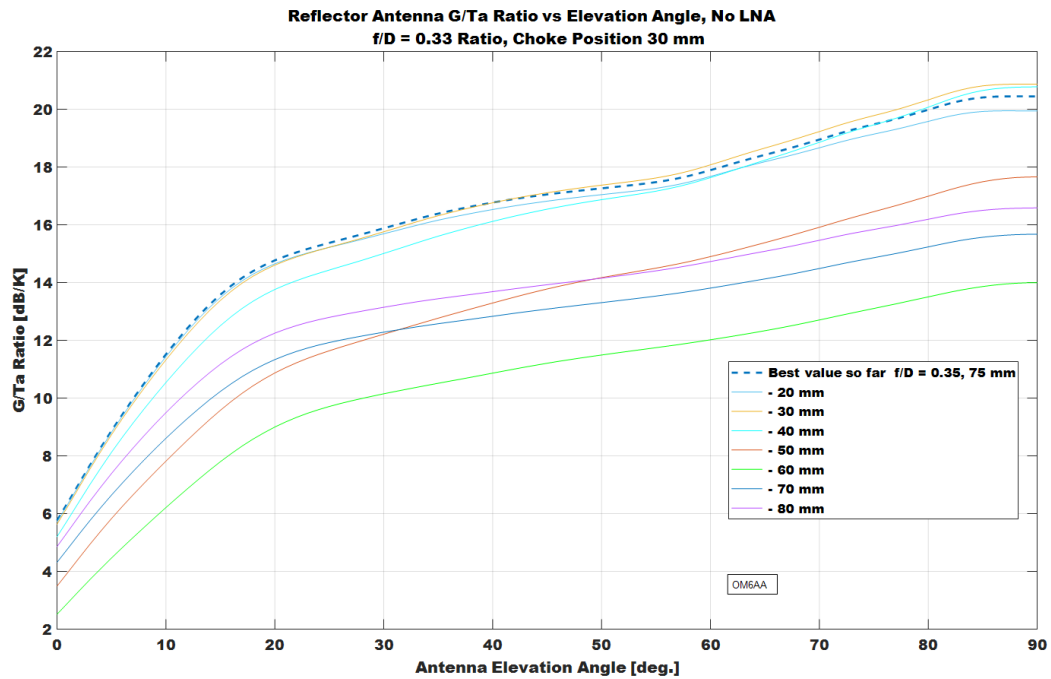

DIFFERENT F/D BETTER?

Feed + Dish
Square to Round taper
Improvement 16 of 16

- $f/d = 0.35$ works well with this feed type. Might a different f/d work better?
- A “deeper” $f/d = 0.33$ dish is slightly better. Shallower dishes (e.g., $f/d > 0.36$) are noticeably worse.
- Varied choke position and focus to confirm behavior.

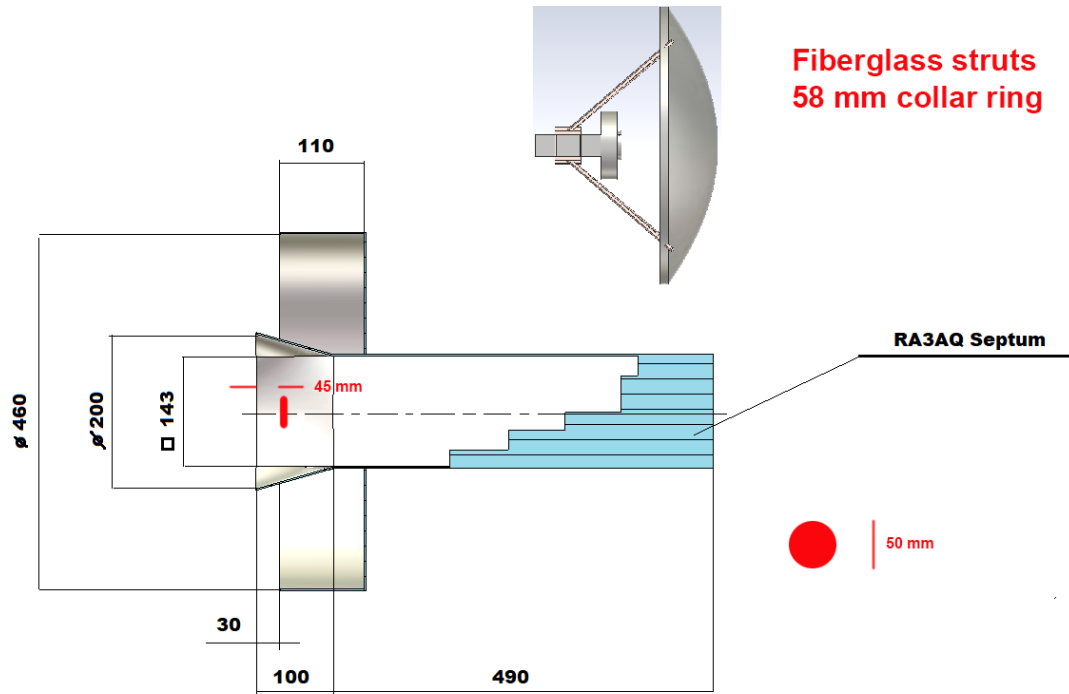

Sun SFU vs
Sun to Cold Sky (dB)

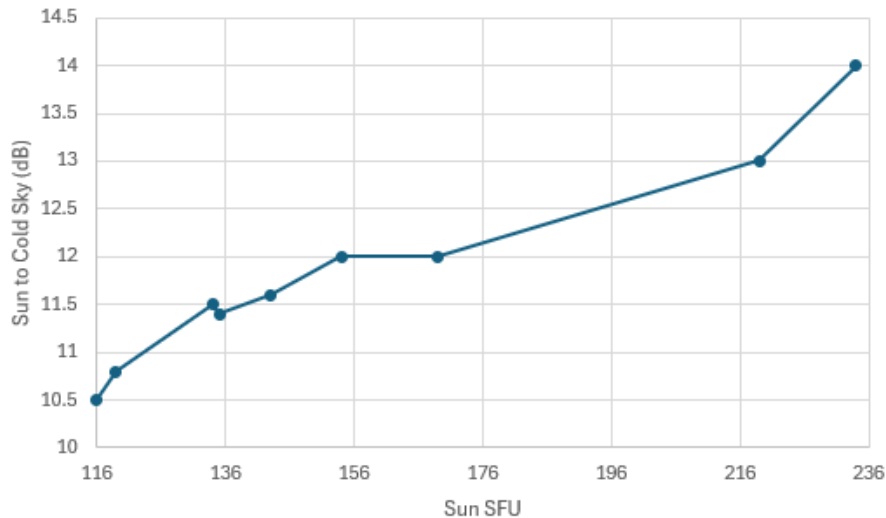

Measured with
SpectraVue

SUN TO COLD SKY

Feed + Dish + S12 Disk
Actual Feed (590mm length)

- Current KB2SA system (2023/2024).
- Sun to cold sky signal measured during 2023/2024 with 1.9m $f/D = 0.35$ mesh wire dish, collar ring, fiberglass struts, 0.25 dB NF LNA and S12 disk.
- *Adjust RF gain as needed so strongest and weakest signals are within the total RX system's linear response region (e.g., no sun saturation).*
- *AGC, Noise Reduction (NR) and Noise Blanking (NB) off. Sun > 40°.*



**1.9M FEED ON
4.88M DISH**

“KB2SA” feed radiation relatively uniform in near, fresnel, and far field

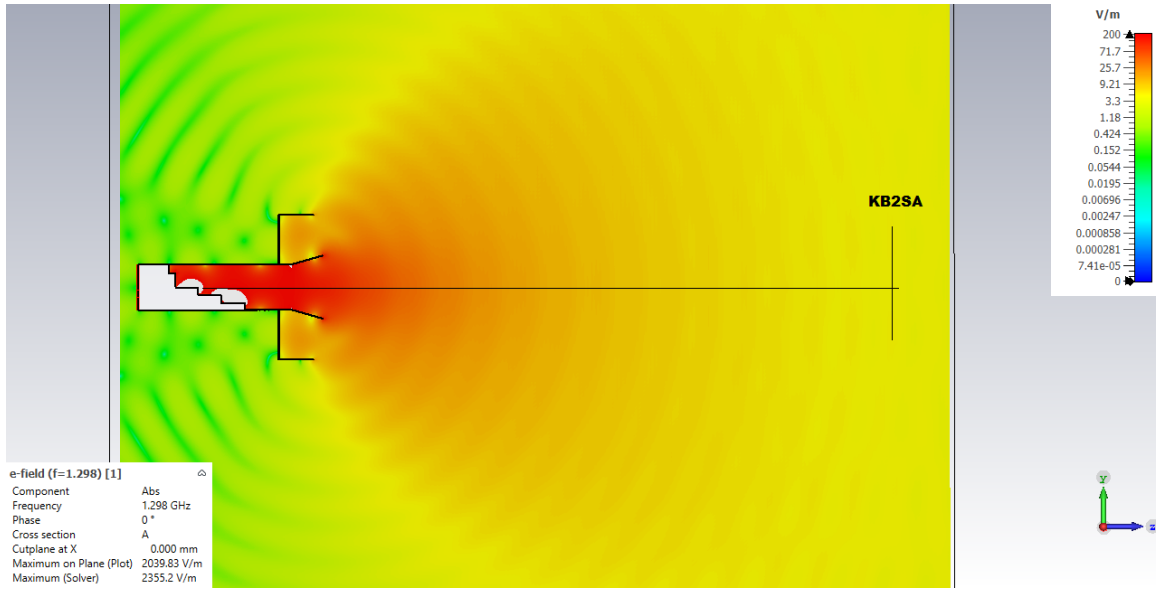

Mats made a polycarbonate cover for tunable S12 disk and birds/insects

1.9M FEED ON 4.88M DISH

Mats Bengtsson, KD5FZX
4.88M Solid, F/D = 0.39
“KB2SA” Feed

- Mats, KD5FZX, expertly constructed the “KB2SA” feed with choke offset tuned to his 4.88M f/d = 0.39 dish.
- The theoretical difference between 1.9m and 4.88m is about 8 dB.
- A 7-8 dB delta is confirmed on both TX and RX with hundreds of QSOs and echo tests.
- We suspect < 1dB loss due to non-optimal f/d = 0.39.



*SSTV EME QSO (Scottie DX)
Martin 2 easily readable*

NOTEWORTHY
1.9M 23CM
QSOS

BH1TSU

TO RADIO *KB2SA*

VIA

ITU-44 CQ-24
Grid: ON80ea

No.27 ChengFang Street
XCheng District
Beijing 100140
China
Mail: zhengqian@gmail.com

I AM HAPPY TO CONFIRM OUR QSO YOUR SWL REPORT

D M Y	UTC	MHz	2-WAY	RST
<i>2/12/2022</i>	<i>07:26</i>	<i>1296.120</i>	<i>Q65-120p</i>	

Propagation EME Topo MS Es

Antennas:

Freq	Antenna	Location
1.8 MHz	CHAMELEON ANTENNA Base HF SKYLOOP 2.0	RX
3.5 MHz	CHAMELEON ANTENNA Base HF SKYLOOP 2.0	Wellbrook
5.3 MHz	CHAMELEON ANTENNA Base HF SKYLOOP 2.0	ALA1530LN
7-50 MHz	Hy-Gain AV-640 HF Vertical Antenna	
144MHz	M2 Antennas 2MCP14	
432MHz	M2 Antennas 430CF30	
1296MHz	Antennas-Amplifiers 2x56 unit Yagi antennas 23cm56AUTHD	

TX QSL
 RSE
 VY731

*Thank you Bill
1.9m Dish - 36 Unit Yagi
CA to Beijing 呼号: 呼号*

NOTEWORTHY 1.9M 23CM QSOS

Timing is everything



CYPRUS

ZC4RH

DAVE HARNETT
Sovereign Base Area
Cyprus

CONFIRMING CONTACT

RADIO	DATE	UTC	MHz	MODE	RST
<i>KB2SA</i>	<i>17/11/22</i>	<i>1018</i>	<i>1296.073</i>	<i>Q65-120D</i>	<i>24-29</i>

- BH1TSU w/36-element yagi
- ZL1NJR w/1.8m folding dish through trees
- ZC4RH w/67-element yagi
- KA1GT w/3.1m dish **and 5 watts**
- DK0TE w/70-element yagi (easy 60C and 30B QSOS)
- WAS #24. **Thank you Peter, KA6U and Gene, KB7Q!**
- 2,895+ QSOS on LoTW
- ARRL International EME Contest, SO-1.2G
 - 2023: #**11**/60
 - 2022: #**13**/43
 - 2021: #**16**/51

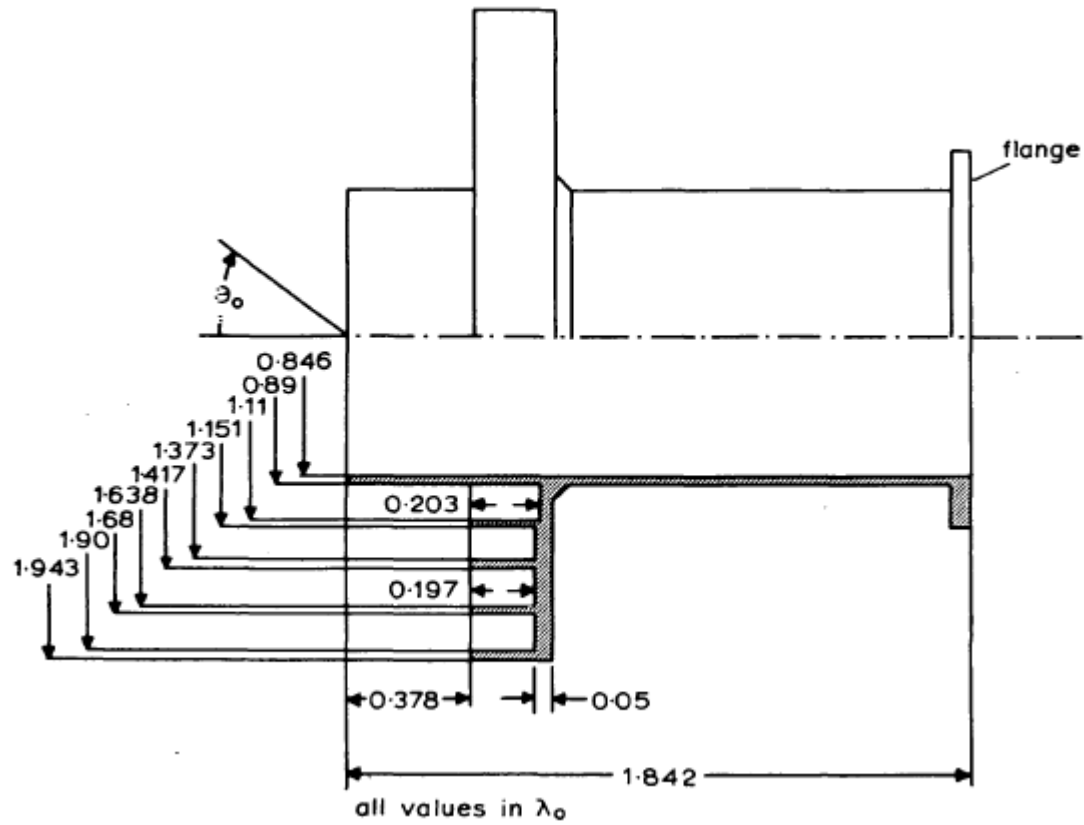

WHAT'S NEXT

LOOK BACK TO LOOK AHEAD

R. WOHLLEBEN
H. MATTES
O. LOCHNER

30th August 1972

Max-Planck-Institut für Radioastronomie
Argelanderstrasse 3
D-53 Bonn, W. Germany

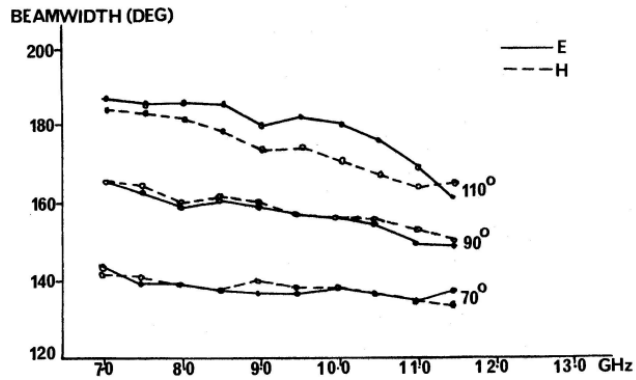

1971

FIG. 2 20 dB BEAMWIDTHS

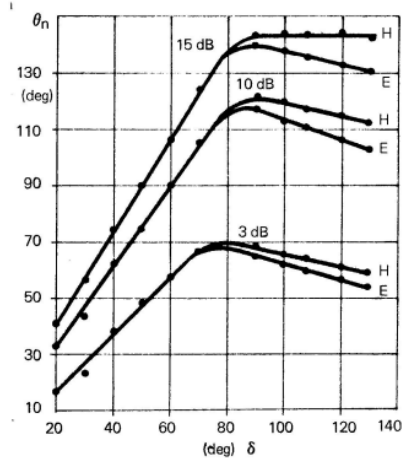
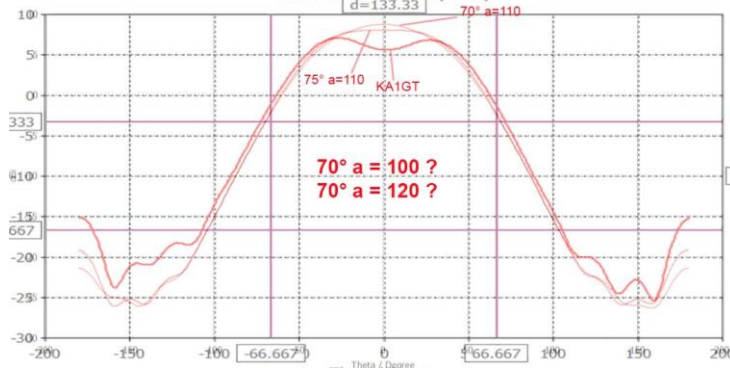
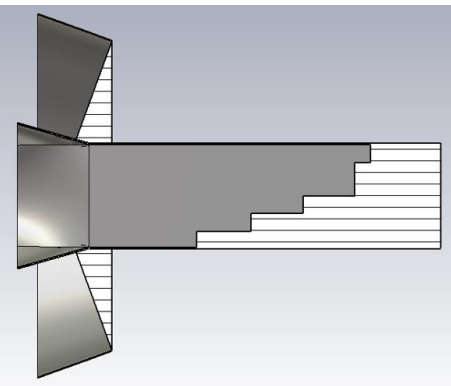

Fig. 4 - Beamwidths at relative power level -3 dB, -10 dB, -15 dB as function of half flare angle. $\alpha \geq 3$

1980

2024



CONVEX CHOKE

Does it improve G/Ts ?

- Experiments by McInnes and Booker in 1971 indicate a 110° choke flare may provide a “fatter” beam.
- A revisit by Pagana and Massaglia in 1980 indicate flares > 90° do not widen beamwidth.
- Simulation in 2024 confirm the 1980 results using different flare angles and choke setbacks. 110° and 105° flare with 110 mm setback shown here. No improvement in G/Ts.

SMALLER CHOKE

Does it improve G/Ts ?

- Might a smaller choke have less obstruction to overcome “non-resonant” losses?
- Preliminary results show no improvement. *More simulation is needed.*
- G/Ta shown here is best so far vs 110° flare with 110 mm setback and 90° flare with 140 mm setback and 373 mm diameter choke.

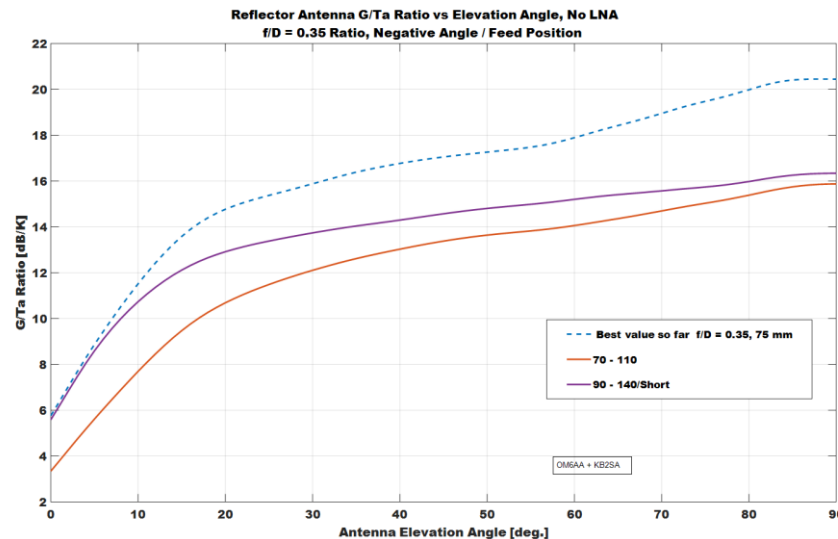
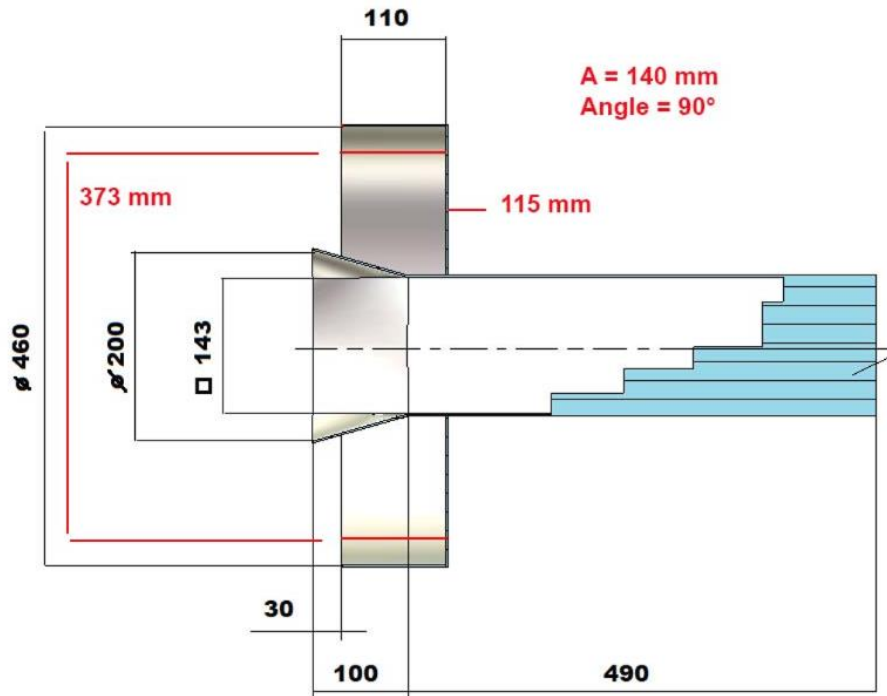

A large, bright full moon is positioned in the upper center of the frame, partially obscured by the dark silhouette of a mountain ridge. The sky is a deep, dusky purple. Below the mountains, a valley contains a small town with several houses and trees. The foreground shows a rocky, sparsely vegetated hillside.

THANK YOU!

**Bill Siino
KB2SA
San Diego, CA**